

MMM Ultrasonic Metallurgy

The quality and competitiveness of casting strongly depends on the quality of molten alloy and the technology used to produce it. With regards to quality, the casting of aluminium alloys is not easy, since alloys are prone to dendritic and heterogeneous structures, as well as the absorption of hydrogen during melting, which requires a specific melt processing operation in order to reduce and control the level of porosity in a microstructure after solidification. By **H. Puga***, **M. Prokic****, **N. van Dongen*****

Aluminium alloys have been gaining increased acceptance as structural materials in the automotive and aeronautical industries, mainly due to their lightweight, good formability and corrosion resistance. However, improvement of mechanical properties is constant in research activities, either by the development of new alloys or by microstructure manipulation.

The aluminium foundry industry have acquired know-how to supply mentioned demanding markets, and it is able to produce high structural quality aluminium based components, by sand, ceramic, die casting or DC casting processes. However, the strict environmental protection regulations, and the increasing costs of raw materials and energy, associated to the increasing advances of emergent countries, expose aluminium industrial activity to enormous risks and strong competitiveness^[1]. Thus, the current challenges that the aluminium foundry industry is facing, requires the development of new manufacturing techniques with high-tech alloys processing parts in order to fulfil the needs of the markets at competitive cost. The development of casting techniques will surely have a positive impact over the life-cycle cost, both in what concerns final products, manufacturing tools and equipment^[1]. Moreover, techniques must focus on decreasing the environmental impact of the activity itself, either by reducing the quantity of raw materials, or

increasing the process yield and reducing energy costs.

High intensity ultrasound applied to non-ferrous alloys melt processing

Ultrasonic degassing/refinement/modification focus on an effective dynamic methodology for degassing metallic melts and to perform microstructural refinement and modification of light alloys, namely aluminium alloys, by applying ultrasonic vibrations after melting and during solidification. This technique improves the mechanical properties of those alloys, avoiding the use of traditional chemical based degassing and refining methodologies, which are less effective and present environmental impact.

Ultrasonic vibrations are proven to be effective in degassing, controlling columnar dendritic structure, reducing the size of equiaxed grains and, under some conditions, producing globular non-dendritic grains, and modifying the eutectic silicon cells in Al-Si alloys. The influence of high intensity ultrasonic vibrations on the microstructural refinement is based on the physical phenomena – cavitation, arising out of high-intensity ultrasound propagation through a liquid^[2].

Cavitation

When a liquid metal is submitted to high intensity ultrasonic vibrations, the alternating pressure above the cavitation threshold creates numerous low-pressure

cavities in a liquid metal, promoting two effects:

(1) Degassing effect: The cavitation achieved by application of ultrasonic vibrations intensifies mass transfer processes and accelerates the diffusion of hydrogen from the melt to the developed bubbles. As acoustic cavitation progresses with time, adjacent bubbles touch and coalesce, growing to a size that allows them to rise up through the liquid, against gravity, until reaching the surface.

(2) Microstructure refinement and modification effect:

The alternating pressure achieved by application of ultrasonic vibrations above the cavitation threshold generates low pressure (almost vacuum) bubbles in a liquid metal, which start growing, pulsing with a continuous expansion/compression regime and finally collapse. During expansion, bubbles absorb energy in the melt, under cooling the liquid at the bubble-liquid interface, resulting in nucleation on the bubble surface. When bubbles collapse, acoustic streaming develops in the melt, distributing the nuclei into the surrounding liquid and producing a significant number of nuclei in the molten alloy, thus promoting heterogeneous nucleation.

Practical problems

Current ultrasonic applications are based on fixed-frequency, well tuned ultrasonic sources, whereby a number of design and matching parameters must be respected,

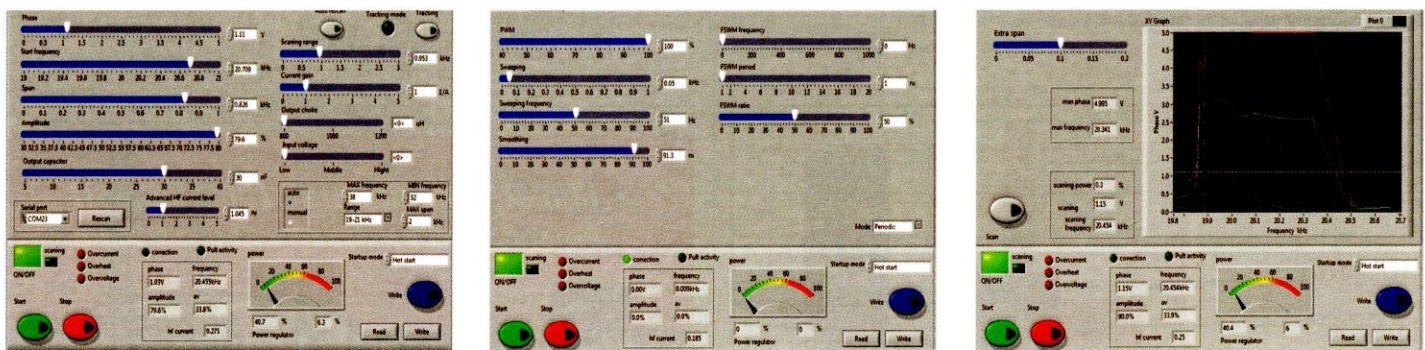

Fig 1. Windows compatible software developed by MPI

*CT2M – Centre for Mechanical and Materials Technologies, University of Minho, Portugal
 MP Interconsulting, Switzerland *Alupro-MPI Ultrasonics Inc., Germany

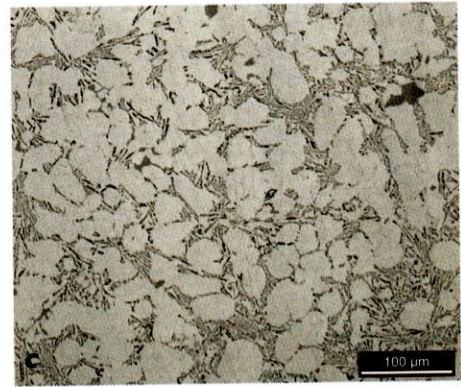
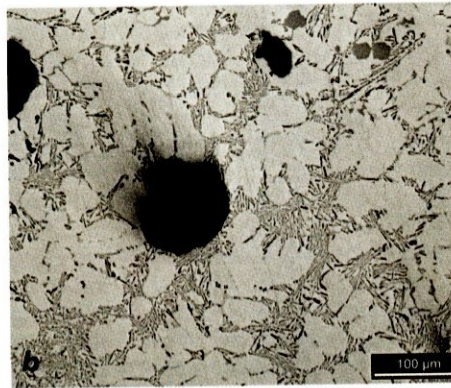
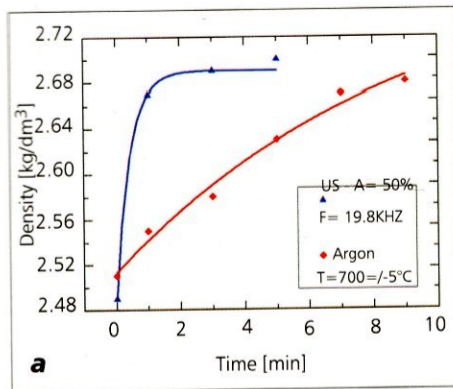

Fig 2. (a) Density of the AlSi9Cu3 alloy as a function of ultrasonic degassing time; (b) porosity in sample before US degassing; (c) porosity in sample after 3 of US degassing

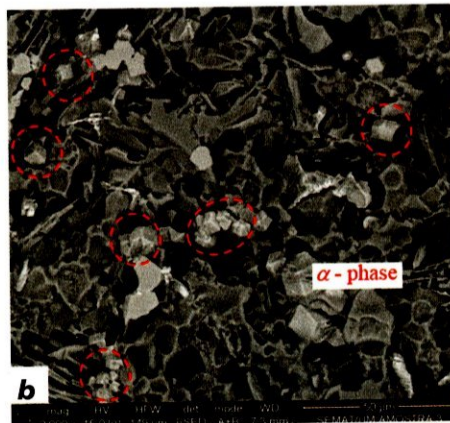
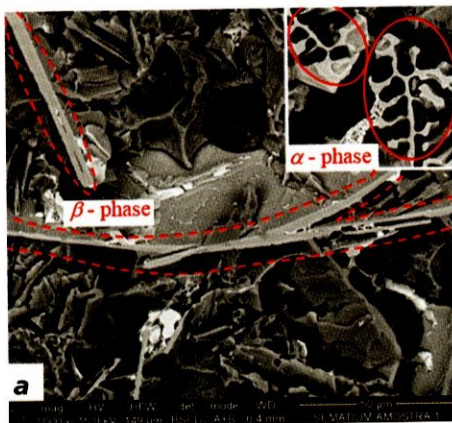

Fig 3. SEM image showing the morphology of intermetallic compounds present in: (a) non-US sample treat; (b) US sample treated

presenting practical and ultrasonic efficiency problems. These basic requirements limit large scale and practical applications in laboratory scale testing. Tests have demonstrated that in order to achieve a high efficiency treatment, ultrasonic systems must be well tuned to the load. Since most ultrasound units work inherently in non-stationary conditions, they must, in theory, continuously adapt themselves to a load to maximise efficiency, which is difficult to achieve with fixed-frequency units. To meet this challenge, Multi-frequency, Multimode, Modulated (MMM) signal processing techniques have been developed by MP Interconsulting^[3].

As a result, MMM technology has become the first to achieve – Wideband-frequency, uniformly spatially distributed, High-power Ultrasonic agitation – in existing metallurgical equipment, regardless of its mass, load size, and particular operating conditions. Moreover, the application of the new signal processing techniques in existing systems does not involve significant design modifications.

MMM technology applied in metallurgy

MMM technology is characterised by synchronously exciting many vibration modes through coupled harmonics and

sub-harmonics in solids and in containers with liquids. This technology produces high intensity multimode vibrations that are spatially uniform and repeatable, this way avoiding creation of stationary and standing waves, so that the whole vibrating system is fully and uniformly agitated, improving the refinement/modification process. The ultrasonic power supply unit is fully controlled by Windows compatible software developed by MPI (Fig 1).

Optimal ultrasonic processing parameters as: Frequency sweeping interval, sweeping repetition rate, and fswm (frequency shift with modulation) for the selected carrier, resonance frequency and electric power are adjusted in order to produce the highest acoustic amplitude and the wide frequency spectrum in the melt, which is monitored with specifically implemented feedback loops^[4]. Thus MMM technology applied to non-ferrous alloys melt treatment can produce metals purification, microstructure refinement, structure modification and degassing, based on the specifically created acoustic field introduced in a molten metal in order to create spatially and uniformly well distributed and wideband multi-frequency cavitation.

During recent years, the technique for melt treatment was developed and applied in non-ferrous alloys^[5,6]. Based on the

results achieved from laboratorial research, a generalised ultrasonic treatment process was extrapolated to be applied on industrial scale.

By applying a different mechanical design and signal processing approach in ultrasonic, laboratorial scale metal processing equipment, it has created refined ultrasonic methodology, whose main advantages are high degassing rate, uniform sonocrystallisation and micro grain refinement; consequently reducing porosity, as shown in Fig 2. On the other hand, this technique doesn't require metal stirring, as the alternative processes, thus it doesn't destroy the protective aluminium oxide present at the surface of the melt, avoiding its introduction in liquid aluminium and keeping its protecting effect against atmospheric contaminants. Moreover, the cavitation effect promotes the wetting and removal of non-metallic inclusions from the melt, playing a major contribution to obtain high quality castings. Additionally, the generated dross is reduced allowing negligible environmental impact.

Beside ultrasonic vibrations to improve castings quality, by promoting melt degassing and the formation of non-dendritic and globular -Al grains, it has also been reported that ultrasonic treatment modified the morphology of intermetallic compounds. Recent results obtained in hypoeutectic Al-Si alloys using MMM technology proved that it is possible to convert the plates of -phase to a fine polyhedral morphology, or to change the morphology of -phase needles to refined Chinese script shaped compounds.

Fig 3(a) and 3(b) show the microstructure of the sample without ultrasonic treatment, and ultrasonically treated by MMM technology, respectively. In samples that were ultrasonically treated by MMM technology the intermetallic particles appear as hexagonal crystals, of which the chemical composition and EDS spectrum were found to be similar to those of the intermetallic -phase present in the non-US treated sample.

Results suggest that the application of

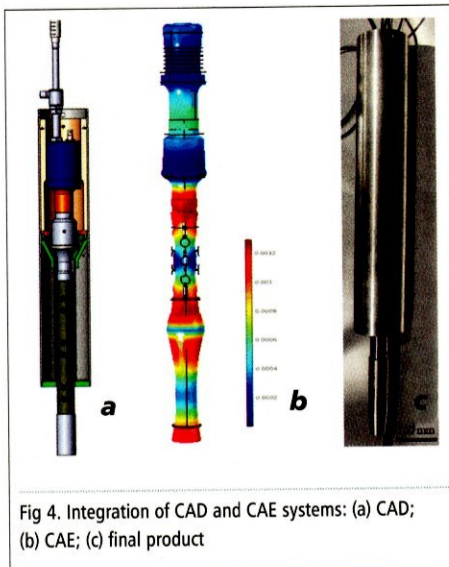

Fig 4. Integration of CAD and CAE systems: (a) CAD; (b) CAE; (c) final product

acoustic energy changes the morphology of the β -phase from a Chinese script shape to polyhedral crystals. Moreover, the formation of β -phase is suppressed, which can be explained by the theory proposed by Narayanan et al.^[7], i.e. if almost all iron is used in the crystallisation of β -phase, when the solidification range of β -phase is finalised, there is no iron available to form this phase, and its experiment doesn't occur.

In conclusion, the experimental results suggest that ultrasonic processing has the potential for a more energy efficient scale-up for production of critical and advanced metal compounds, leading to cost reductions, energy savings, and many other benefits.

Stepping from the laboratorial experiment to an industrial environment

A comprehensive experimental study on the aluminium melt treatment through ultrasonic system based on MMM technology has been developed and discussed during the last several years. The main objective is to provide an experimental verification and validation of the theoretical mechanisms, as well as to verify the resistance and reliability of MMM technology components. This experimental procedure complements the theoretical and laboratorial studies in the literature, and provides an appropriate knowledge for continuous innovation in relevant industrial activities including design, construction and applications of ultrasonic vibration equipment based on MMM technology.

MP Interconsulting^[8] has been developing ultrasound equipment for use in the metal processing industry. The company is promoting an integration of CAD and CAE systems (Fig 4) in the search for optimal ultrasonic processor performances from design to manufacturing. According to different criteria, laboratorial pre-established

methodologies, mathematical concepts, and a number of successfully realised applications, the process of creating and delivering ultrasonic vibrations to liquid metals is optimised. Fig 5 shows an example of modern methods and ultrasonic equipment applied in industrial environment.

Fig 6 shows the variation of hydrogen content in the melt of alloy of the series 3xxx along of time in Continuous casting with a maximum flow rate of 1.1 m/minute. The hydrogen content was measured with the "Alu Speed Tester" equipment based on the first gas bubble principle. The results show that the use of the innovative and sophisticated ultrasonic equipment based in MMM technology and with ceramic sonotrode radiator (according Fig 5(a)) is possible to remove 45-50% of hydrogen under the following parameters: $f=20.3 \pm 0.1$ kHz (stable in time), $A=50\%$ and $T=700 \pm 5^\circ\text{C}$.

Conclusions

The ultrasonic processing technique for melt treatment was developed and applied in different non-ferrous alloys. Based on the results achieved for different alloys, the main conclusions that can be drawn are:

- (1) Ultrasonic degassing can be an efficient process to degas molten non-ferrous alloys in industrial scale.
- (2) When compared with the traditional, fixed-frequency ultrasonic processors, MMM ultrasonic technique seems to improve the ultrasonic degassing process by increasing the final alloy density and degassing rate.
- (3) Ultrasonic processing by MMM technology is an external supply of energy – presenting physical process – environmentally clean and efficient that promotes uniform refinement of primary grains, modifications of intermetallic phases and eutectic Si, and decrease of porosity in non-ferrous alloys.
- (4) Ultrasonic treatment clearly improves final mechanical properties and fluidity of treated alloys. ■

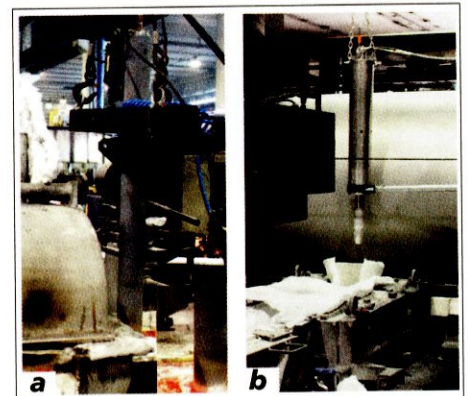

Fig 5. Different design options applied in industrial environment during Continuous casting: (a) degassing system; (b) refinement system

References

- [1] European Commission. Integrated Pollution Prevention and Control: Best Available Techniques in the Smitheries and Foundries Industry. (2005).
- [2] Eskin, G. I. Cavitation mechanism of ultrasonic melt degassing. *Ultrasonics Sonochemistry* 2, S137-S141, doi:http://dx.doi.org/10.1016/1350-4177(95)00020-7 (1995).
- [3] Prokic, M. (European Patent Application, 2001).
- [4] Prokic, M. Wideband Multi-Frequency, Multimode, and Modulated (MMM) Ultrasonic Technology. 125-140, doi:10.1007/978-1-4419-7472-3_5 (2011).
- [5] Puga, H., Barbosa, J., Seabra, E., Ribeiro, S. & Prokic, M. The influence of processing parameters on the ultrasonic degassing of molten AlSi9Cu3 aluminium alloy. *Materials Letters* 63, 806-808 (2009).
- [6] Puga, H., Costa, S., Barbosa, J., Ribeiro, S. & Prokic, M. Influence of ultrasonic melt treatment on microstructure and mechanical properties of AlSi9Cu3 alloy. *Journal of Materials Processing Technology* 211, 1729-1735 (2011).
- [7] Narayanan, L. A., Samuel, F. H. & Gruzleski, J. E. Crystallization behavior of iron-containing intermetallic compounds in 319 aluminum alloy. *Metallurgical and Materials Transactions A* 25, 1761-1773, doi:10.1007/BF02668540 (1994).
- [8] <http://www.ultrasonicmetallurgy.com/>

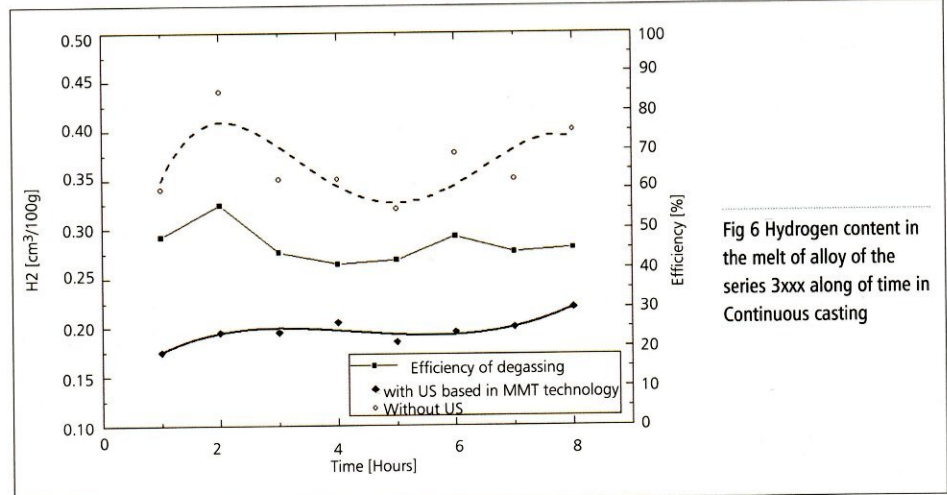

Fig 6 Hydrogen content in the melt of alloy of the series 3xxx along of time in Continuous casting



KELK
Sensors for Rolling Mills



ACCUSPEED Laser Velocimeter

- Elongation Control
- Cut-to-Length Control
- Automatic Width Control
- Flaw tracing for Surface Inspection
- Mass Flow Automatic Gage Control
- Transfer bar tracking for Crop Optimization

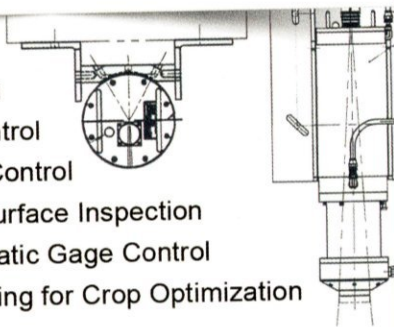

Vishay Precision Group Canada ULC (KELK)
T: +1 416 445 5850 www.kelk.com F: +1 416 445 5972



mpi ultrasonics
www.Ultrasonic-Metallurgy.com
www.MPI-Ultrasonics.com
MPI@MPI-Ultrasonics.com

Ultrasonic Processing in Metallurgy

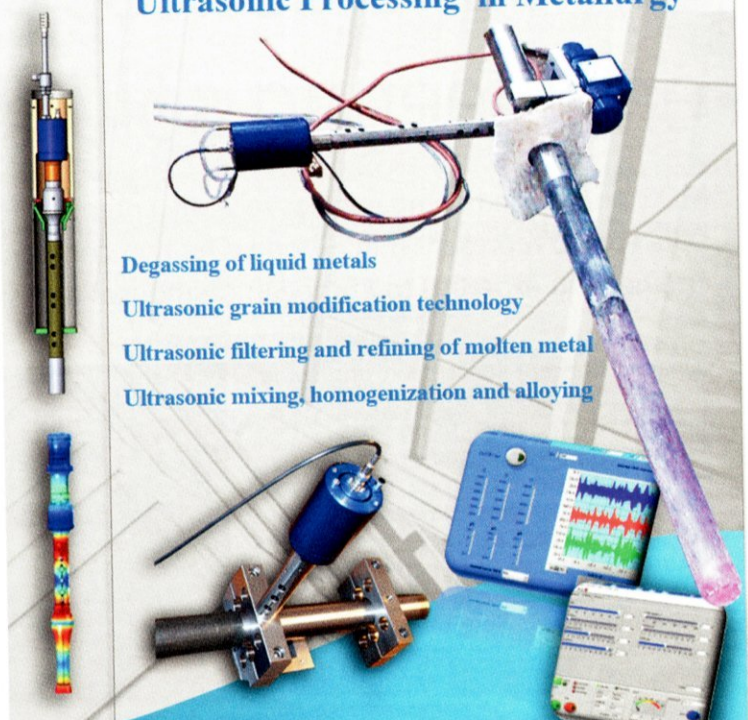

- Degassing of liquid metals
- Ultrasonic grain modification technology
- Ultrasonic filtering and refining of molten metal
- Ultrasonic mixing, homogenization and alloying

MMM: Multifrequency Multimode Modulated ultrasonics.
Our Imagination is the only limit!

+ TUF FILTRATION

DE filtration technology has a lot of holes in it.

Reduce rolling fluid processing costs and HSE issues
with Tough Ultra Filtration (TUF™) technology from CRS.



Improve the quality and volume of recovered oil with TUF, an advanced filtration solution that eliminates the need for costly DE and disposable filter media. Customizable to meet each application's requirements, TUF is a proprietary, service-based offering that lowers operational costs, improves product quality and helps achieve environmental improvement goals.

For detailed information on advanced filtration and
recovery solutions from CRS, visit www.EliminateDE.com.



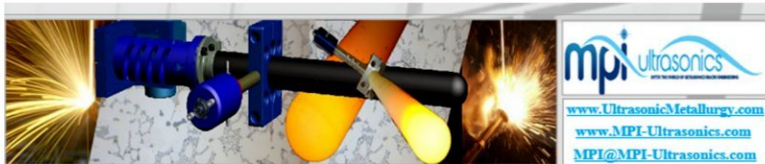

Ultrasonic Processing in Metallurgy



Degassing of liquid metals

Ultrasonic grain modification technology

Ultrasonic filtering and refining of molten metal

Ultrasonic mixing, homogenization and alloying

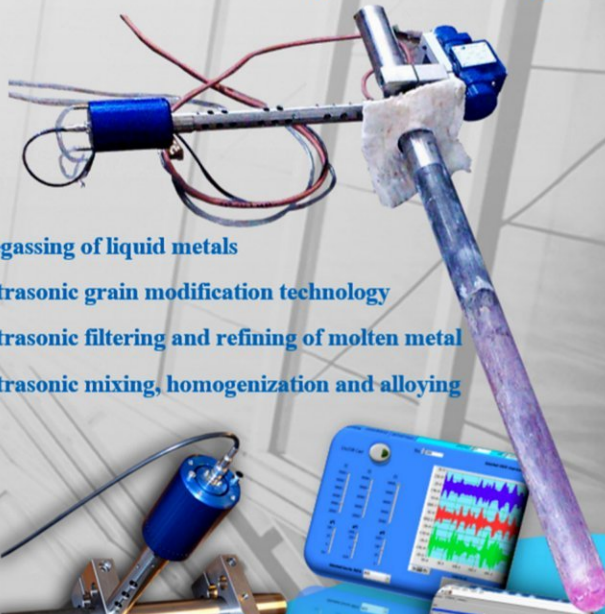
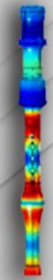

MMM: Multifrequency Multimode Modulated ultrasonics.

Our Imagination is the only limit!

May/June 2014

Volume 26 No 3

Promoting the aluminium industry for **25** years

THE JOURNAL OF ALUMINIUM PRODUCTION AND PROCESSING

ALUMINIUM INTERNATIONAL **TODAY**



EGA

الإمارات العالمية للألمنيوم
EMIRATES GLOBAL ALUMINIUM

شركات الإمارات العالمية للألمنيوم
EGA Companies

dubal

emal

NEWS • CASTHOUSE • ENVIRONMENT