



INDUSTRIAL ADDITIVE TECHNOLOGY

- **DEVELOPMENT**
- **IMPLEMENTATION**
- **MANUFACTURING**



MISSION

CREATION OF THE HI-TECH DIGITAL ADDITIVE MANUFACTURING ON THE BASIS OF MODULAR PRODUCTION-TECHNOLOGICAL COMPLEXES.

OBJECTIVES

- REDUCTION OF TERMS OF PRODUCTION PREPARATION OF SINGLE EXEMPLARS, SMALL SERIES OF PARTS FOR RESEARCH AND TECHNICAL DEVELOPMENT
- REDUCTION OF TERMS OF BATCH PRODUCTION PREPARATION
- DECREASING OF LABOR CONSUMPTION OF BATCH PRODUCTION
- MANUFACTURING OF COMPETITIVE PRODUCTS
- REDUCTION OF THE NUMBER OF TECHNOLOGICAL PROCESSES
- FLEXIBLE RECONFIGURATION OF PRODUCTION CAPACITIES FOR THE DEVELOPMENT OF NEW PRODUCTS WITHOUT TECHNOLOGICAL READJUSTMENT OF MANUFACTURING AT ANY STAGE OF DEVELOPMENT AND MASS PRODUCTION



APPLICATION AREA OF DIGITAL ADDITIVE MANUFACTURING





THE VISION OF ADDITIVE MANUFACTURING

- ADDITIVE THINKING
- ADDITIVE DEVELOPMENT
- ADDITIVE MATERIALS
- ADDITIVE EQUIPMENT
- ADDITIVE TRAINING





THE VISION OF ADDITIVE MANUFACTURING «DIRECT DIGITAL MANUFACTURING»

DIGITAL DATA

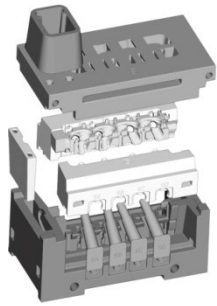

CAD/CAM/CAE

EQUIPMENT OF ADDITIVE MANUFACTURING



PRODUCTS

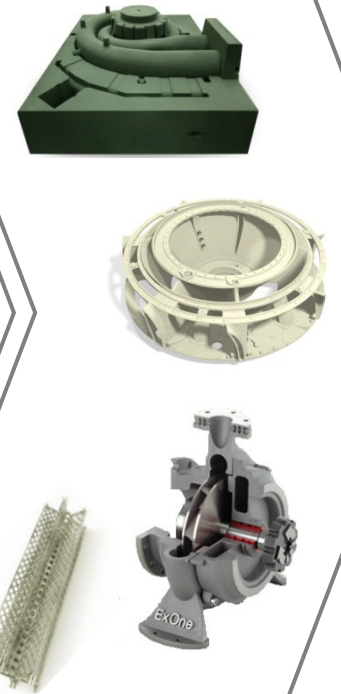



DIGITAL ADDITIVE TECHNOLOGY

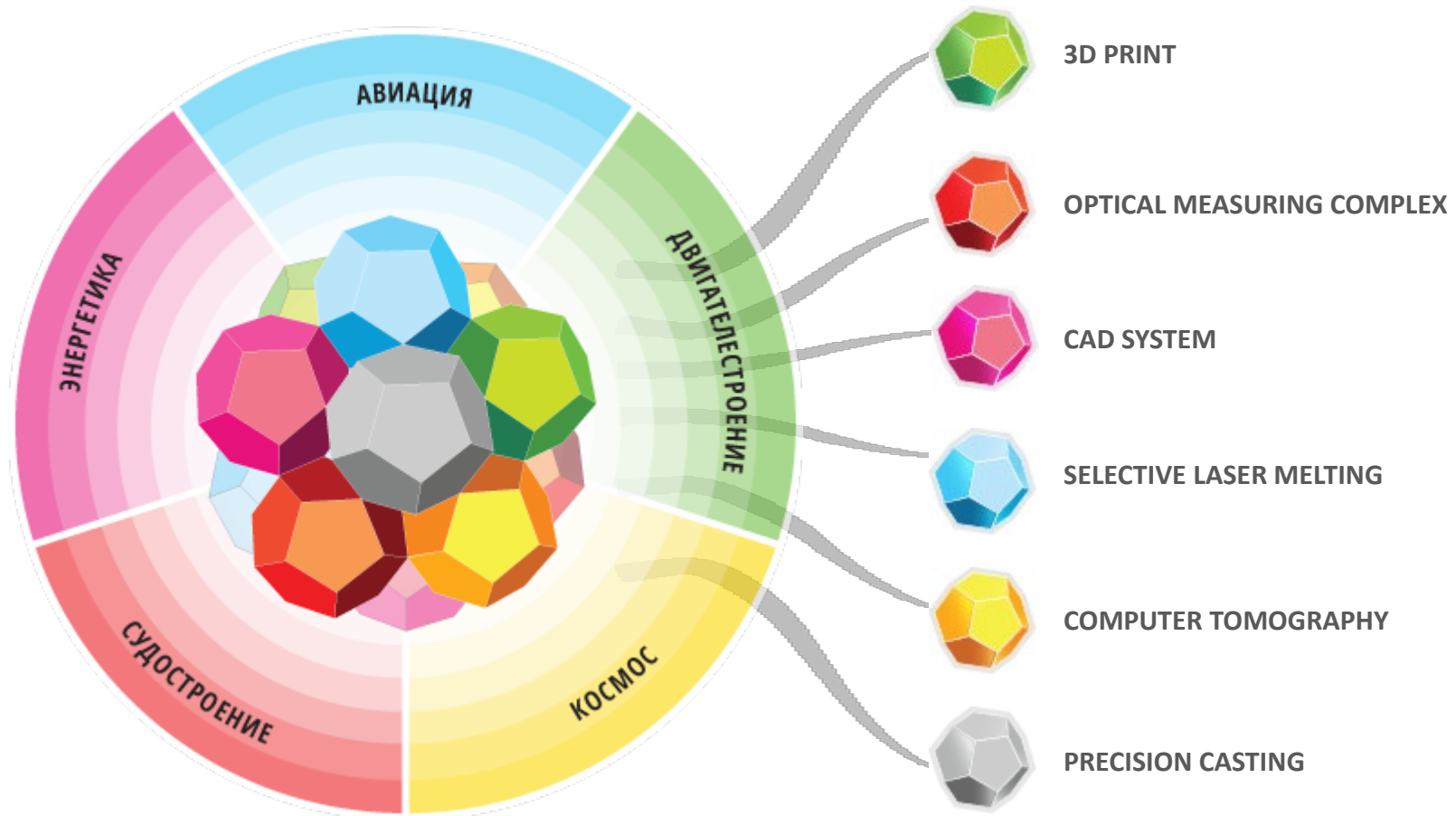



3D ПЕЧАТЬ



MATERIALS

EQUIPMENT

CASTING

ENGINEERING

MATERIALS

PROTOTYPING

DEVELOPMENT

MANUFACTURING

TRAINING





СЕЛЕКТИВНОЕ ЛАЗЕРНОЕ ПЛАВЛЕНИЕ

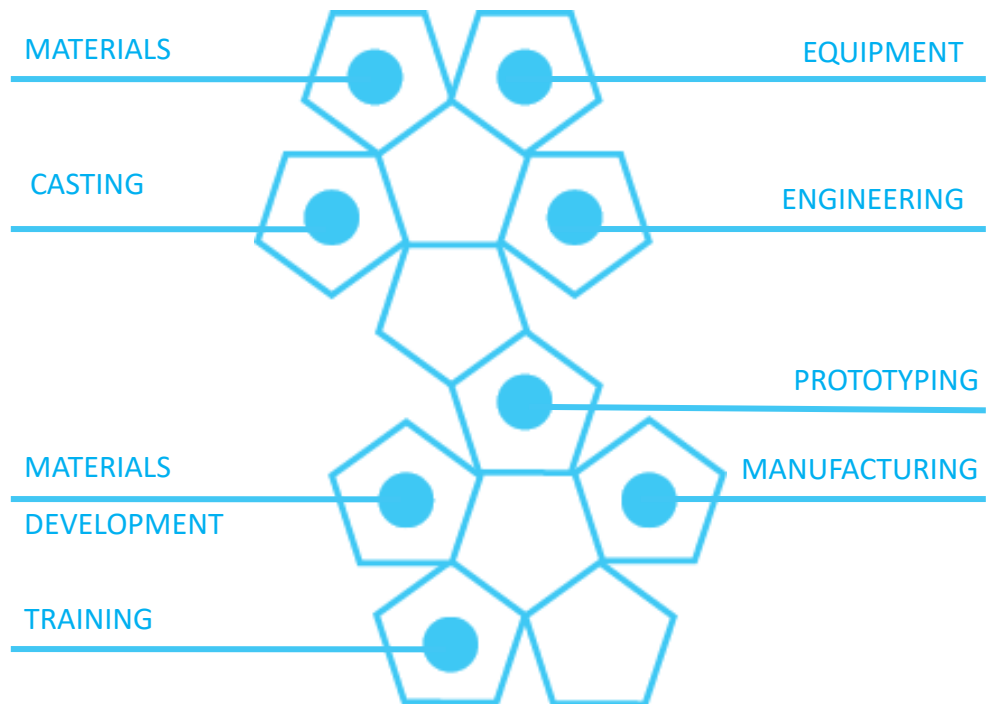



MODULAR CASTING PRODUCTION

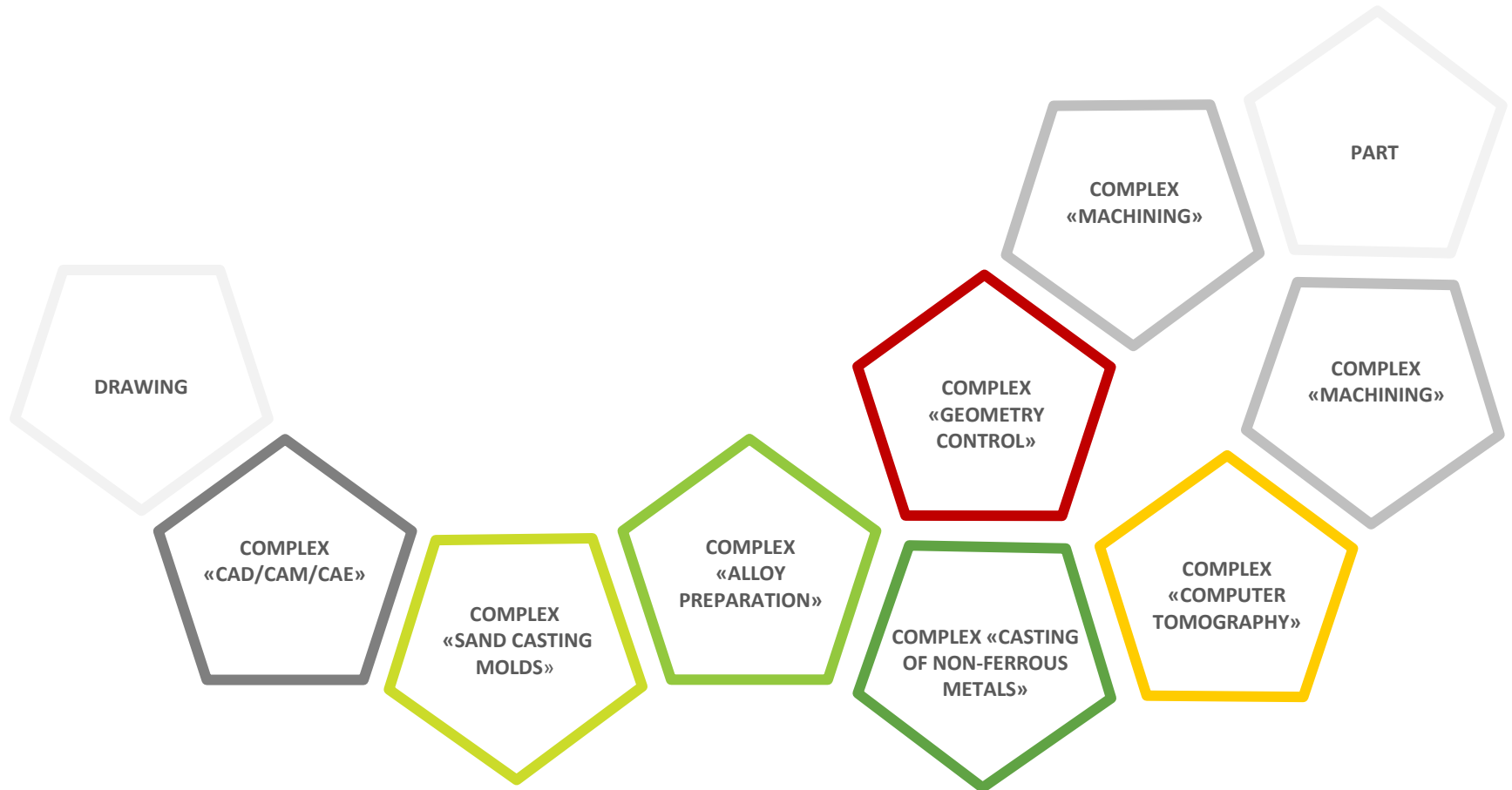



THE VISION OF MODULAR MANUFACTURING ON THE BASIS OF DIGITAL ADDITIVE TECHNOLOGY

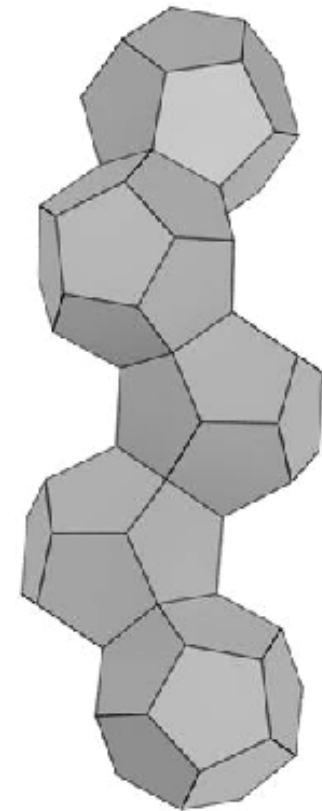



REDUCTION OF TERMS OF PRODUCTION PREPARATION

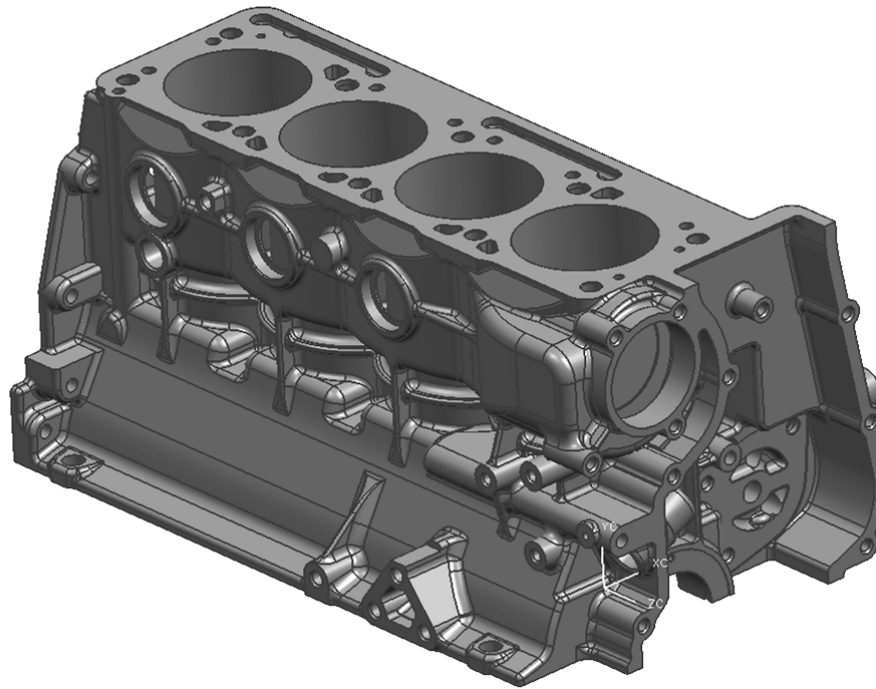

ADDITIVE MANUFACTURING
TECHNOLOGY OF SAND CASTING
MOLDS

DOSED CASTING UNDER LOW
PRESSURE

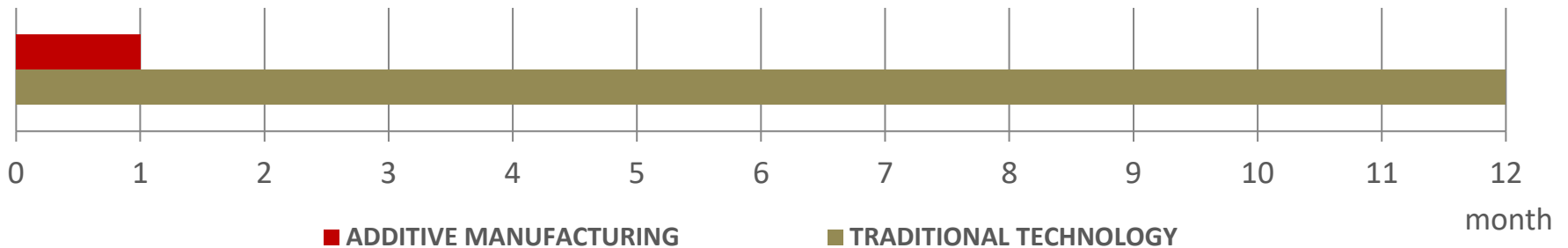



TRADITIONAL MANUFACTURING PROCESS OF SAND MOLDS

Core boxes with a complex forming elements

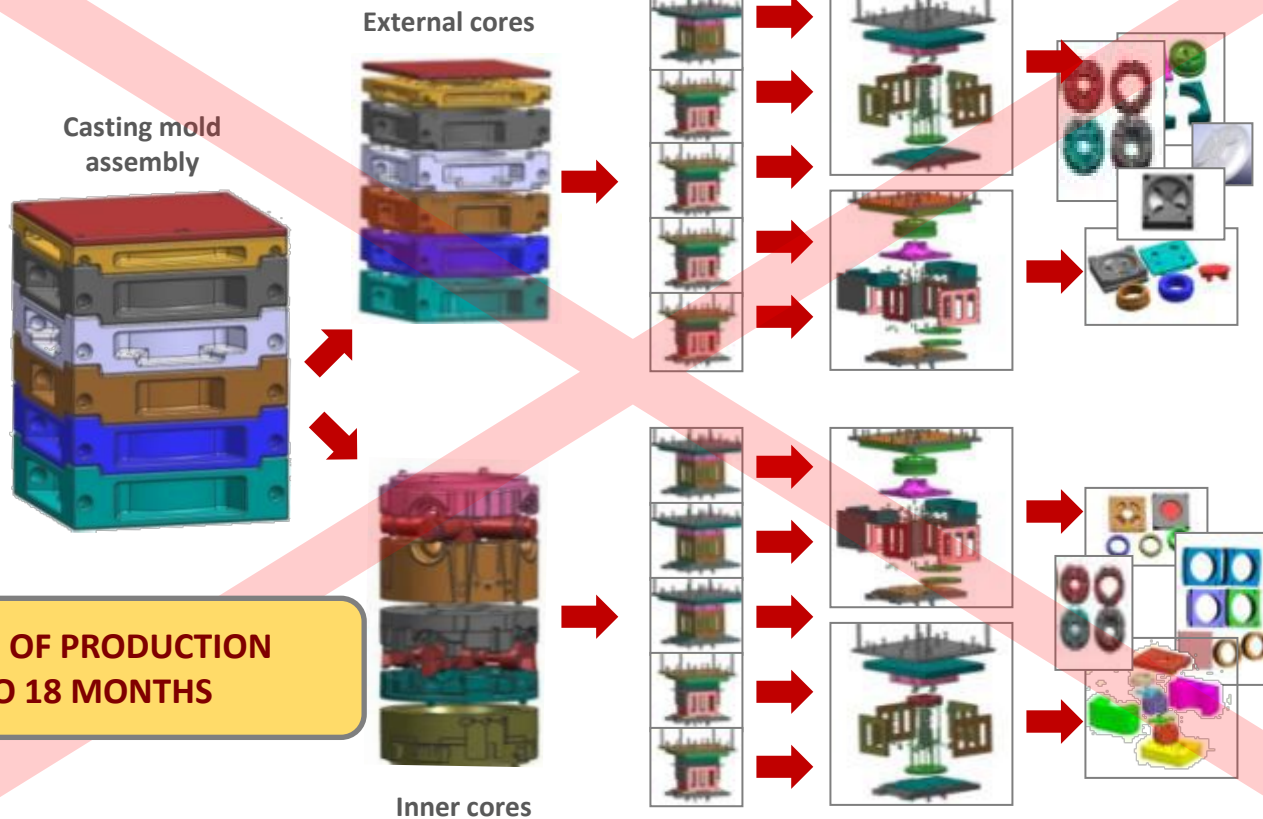

**PREPARATION OF PRODUCTION
FROM 6 TO 18 MONTHS**



DEVELOPING OF CASTING MOLDS

Digital technology

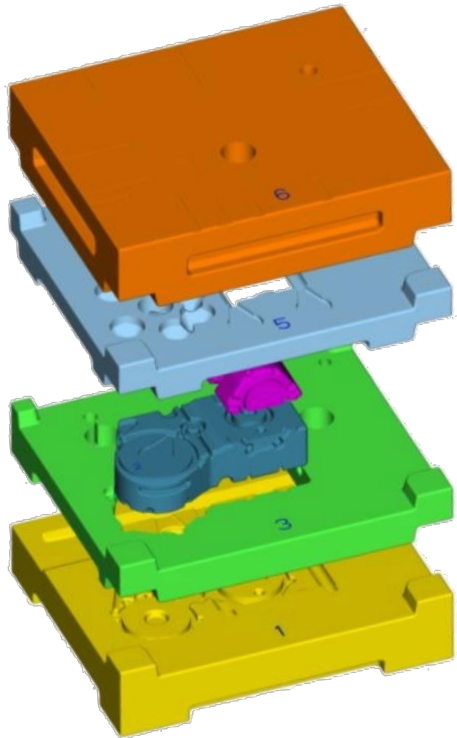

Sand-polymeric mold
Mold dimensions – 600 x 500 x 380 mm.

Mold structure – 6 cores

Traditional technology

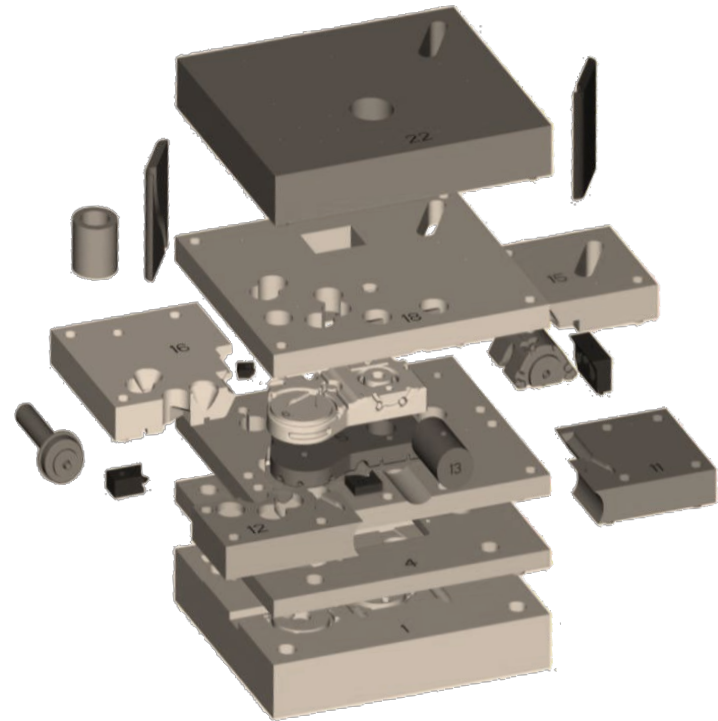

Sand-polymeric mold
Mold dimensions – 600 x 500 x 380 mm.

Mold structure – 23 cores



DIGITAL ADDITIVE TECHNOLOGY



EQUIPMENT FOR 3D-PRINTING

- POLYMER POWDER MATERIALS
- METAL POWDERS
- QUARTZ SAND
- CERAMIC POWDER MATERIALS



EQUIPMENT FOR SELECTIVE LASER MELTING

- POLYMER POWDER MATERIALS
- METAL POWDERS



ULTRASONIC TECHNOLOGY

- CASTING TECHNOLOGY
- INTENSIFICATION OF PROCESSES
- CONTROL

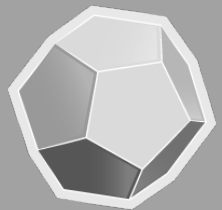

EQUIPMENT FOR PRECISION CASTING

- NON-FERROUS METALS
- FERROUS METALS



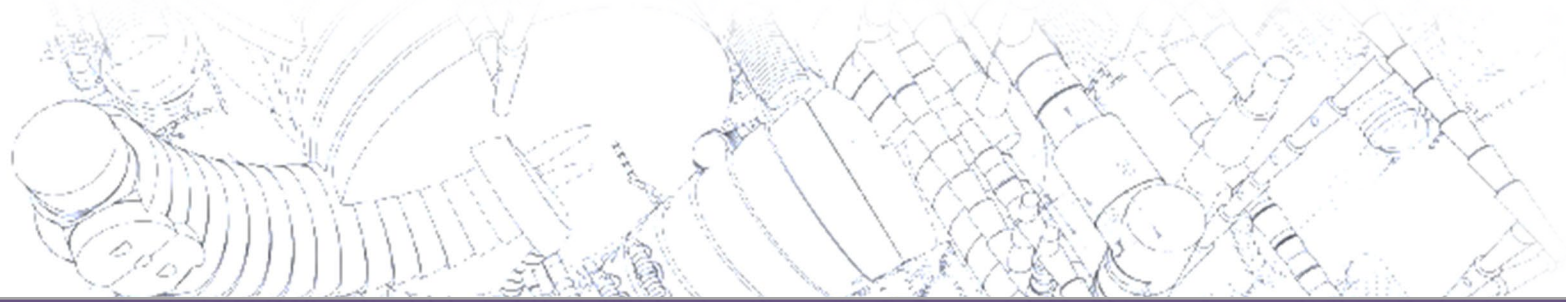

«CAD/CAM/CAE»

- ADDITIVE ENGINEERING
- PROTOTYPING
- MODELLING

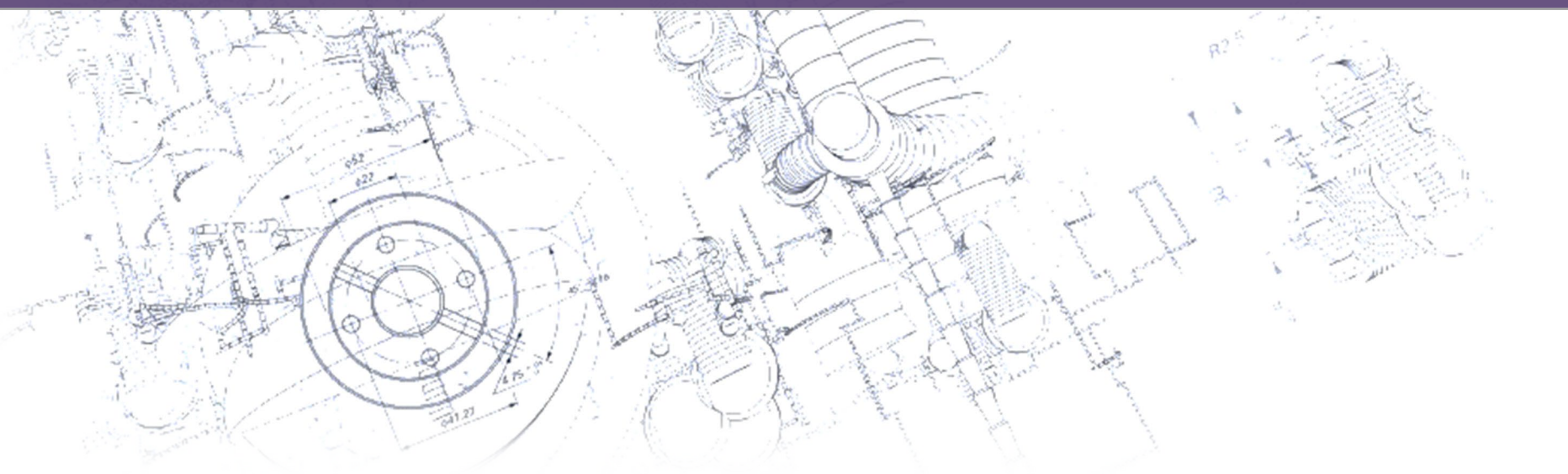



COMPLEX «CAD/CAM/CAE»

ENGINEERING DEPARTMENT ON THE DESIGN OF CASTINGS, TOOLING AND
DEVELOPMENT OF PRODUCTION TECHNOLOGY

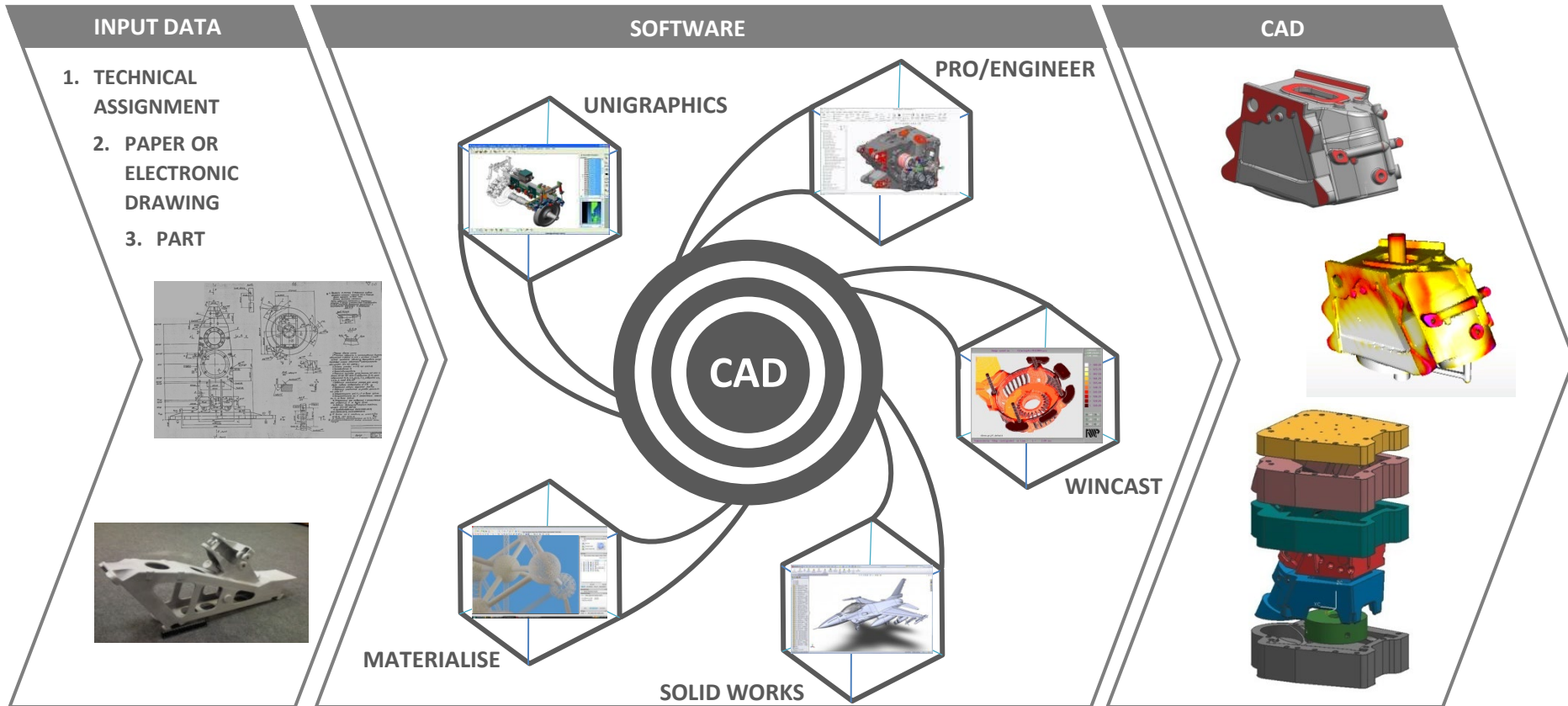



DESIGN BASED ON ADDITIVE TECHNOLOGIES

TRADITIONAL TECHNOLOGY

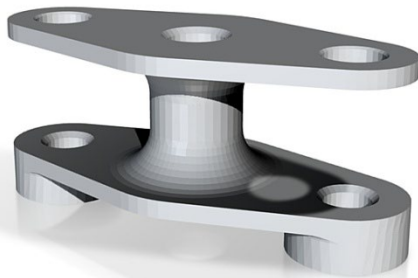
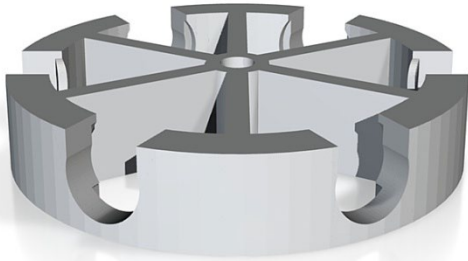

ADDITIVE TECHNOLOGY

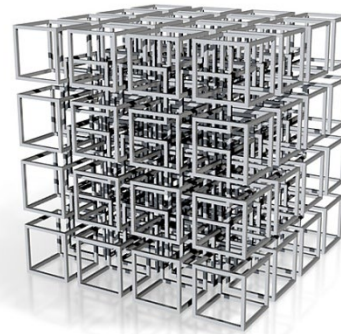
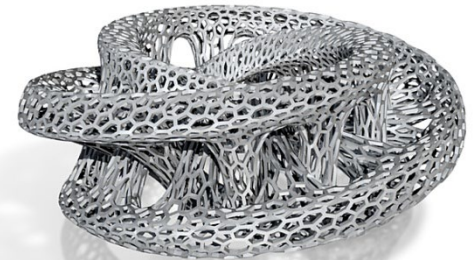



DESIGN OPTIMIZATION

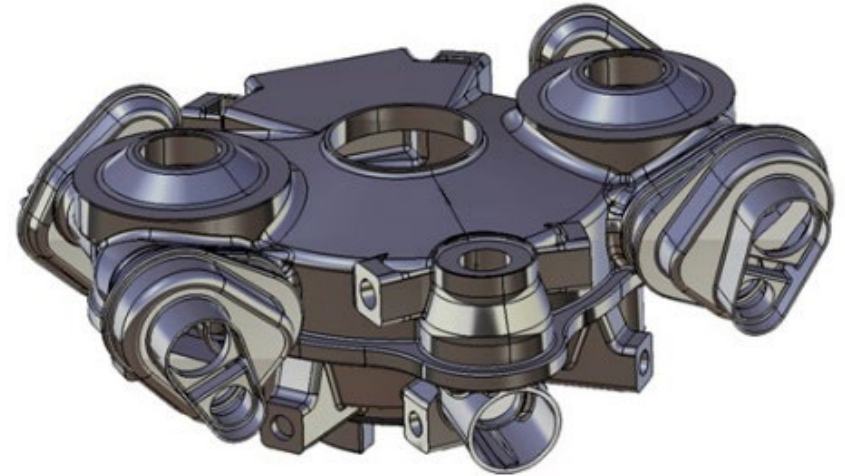



MODELING OF CASTING

Time: 0.003s

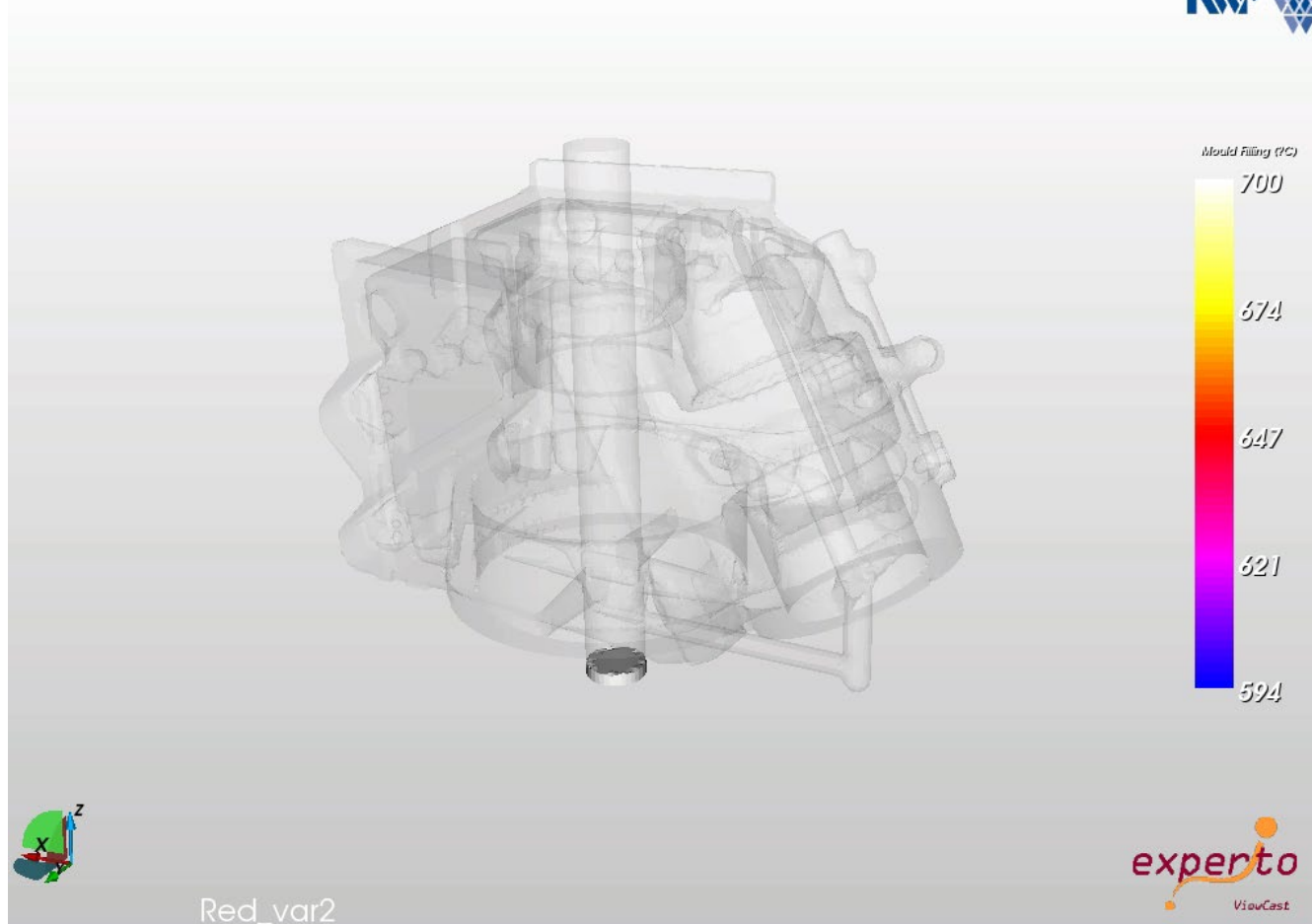



TRADITIONAL SAND CASTING MOLD

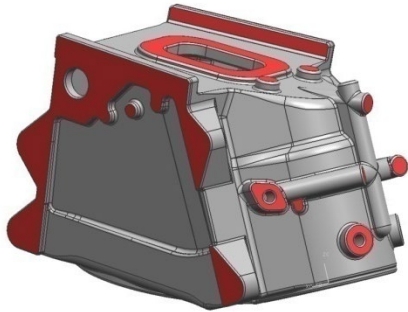

Dimensions :
480 x 370 x 280 mm
Weight : 15 kg

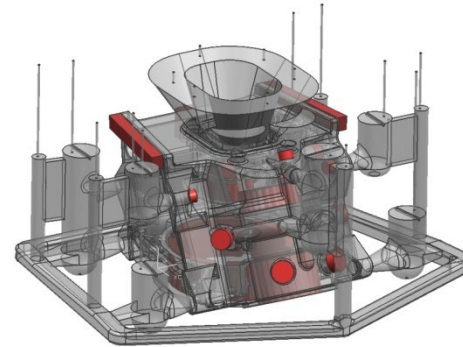

Dimensions :
650 x 590 x 376 mm
Weight : 33 kg

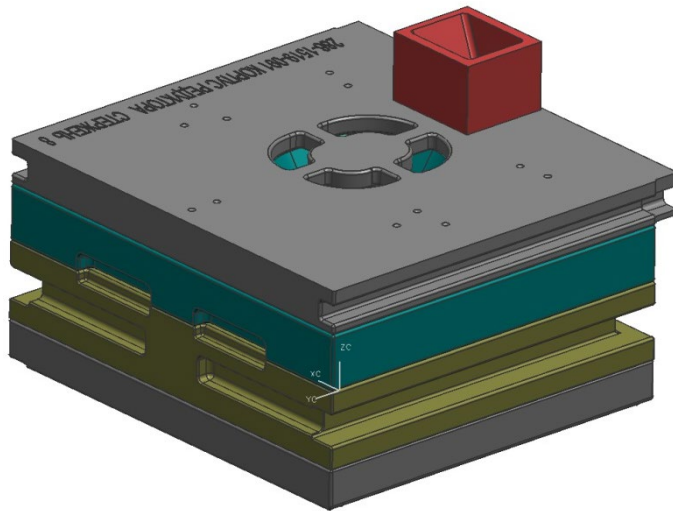

Dimensions:
850 x 750 x 400 mm
Weight : 400 kg

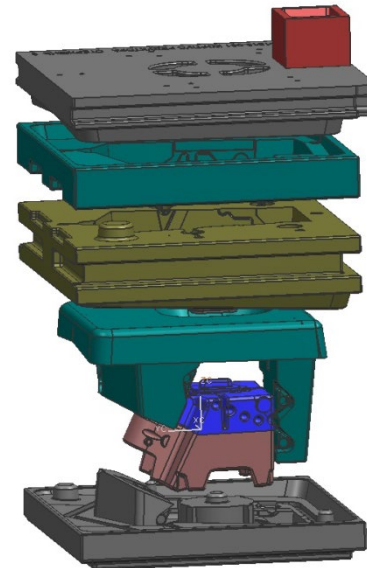

Total of cores :
9 pcs.
Weight of cores:
- Minimum 10 kg
- **Maximum 82 kg**



SHELL SAND CASTING MOLD

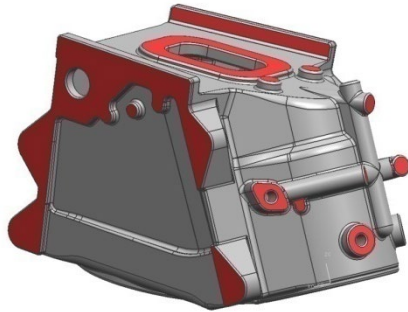

Dimensions :
480 x 370 x 280 mm
Weight : 15 kg

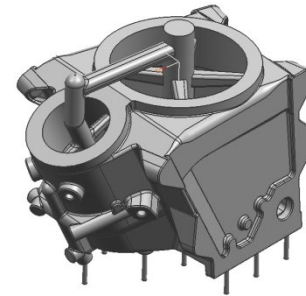

Dimensions :
405 x 347 x 300 mm
Weight : 17 kg

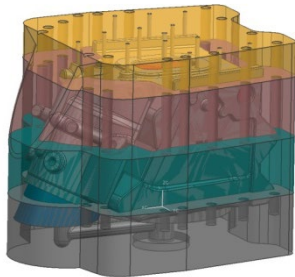

Dimensions :
530 x 415 x 380 mm
Weight : 105 kg

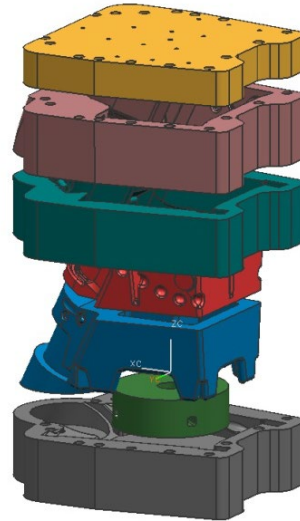

Total of cores : 7 psc
Weight of cores :
- Minimum 3 kg
- Maximum 20 kg

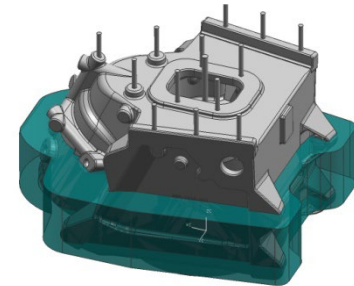

External cores:
Wall thickness from 30 to 50 mm

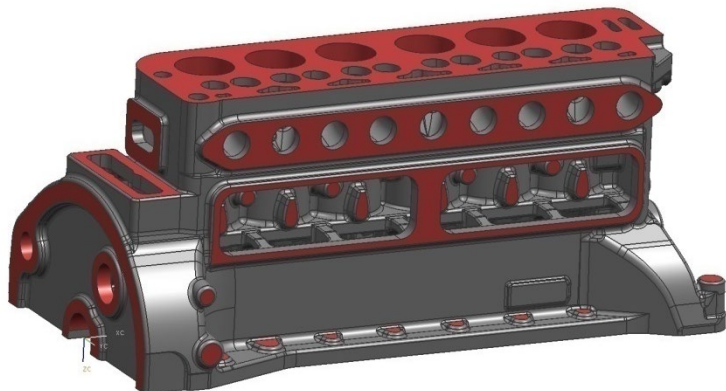

Dimensions :
800 x 405 x 335 mm
Casting weight : about 150 kg

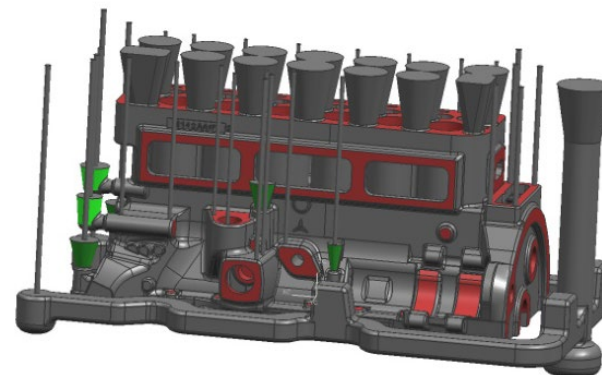

Dimensions :
1000 x 575 x 520 mm
Casting weight : about 280 kg

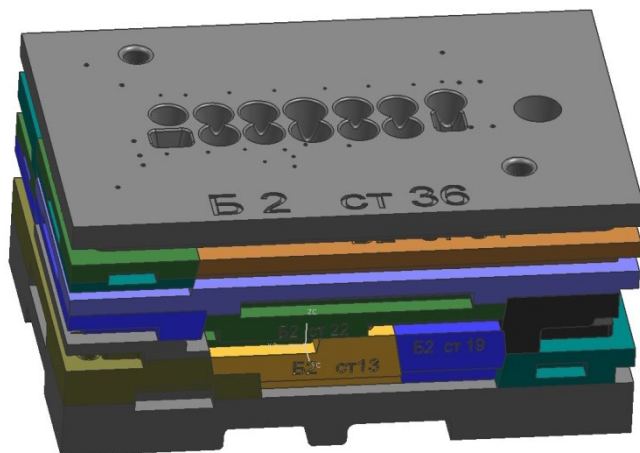

Dimensions :
1200 x 745 x 565 (Z) mm
Weight of assembled mold : около 600 kg

Total of cores : 42 psc.

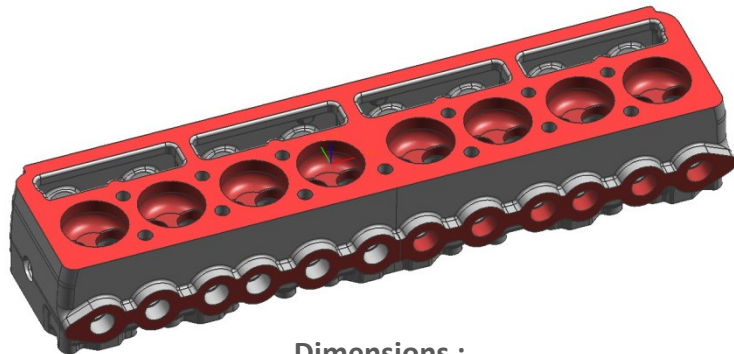

Dimensions :
890 x 210 x 140 mm
Casting weight : 79 кг

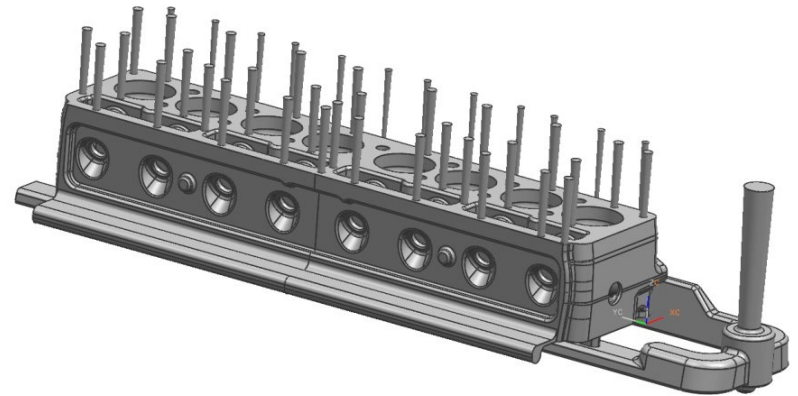

Weight of casting with sprues :
120 кг

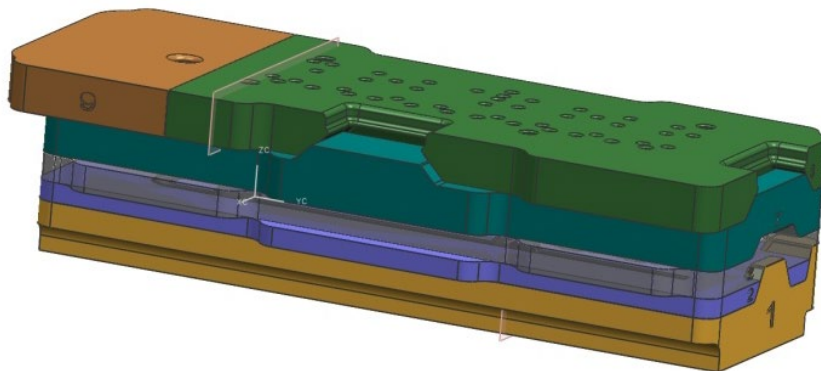

Dimensions :
1520 x 600 x 380 mm
Weight of assembled mold : около 380 кг

Total of cores : 18 шт.

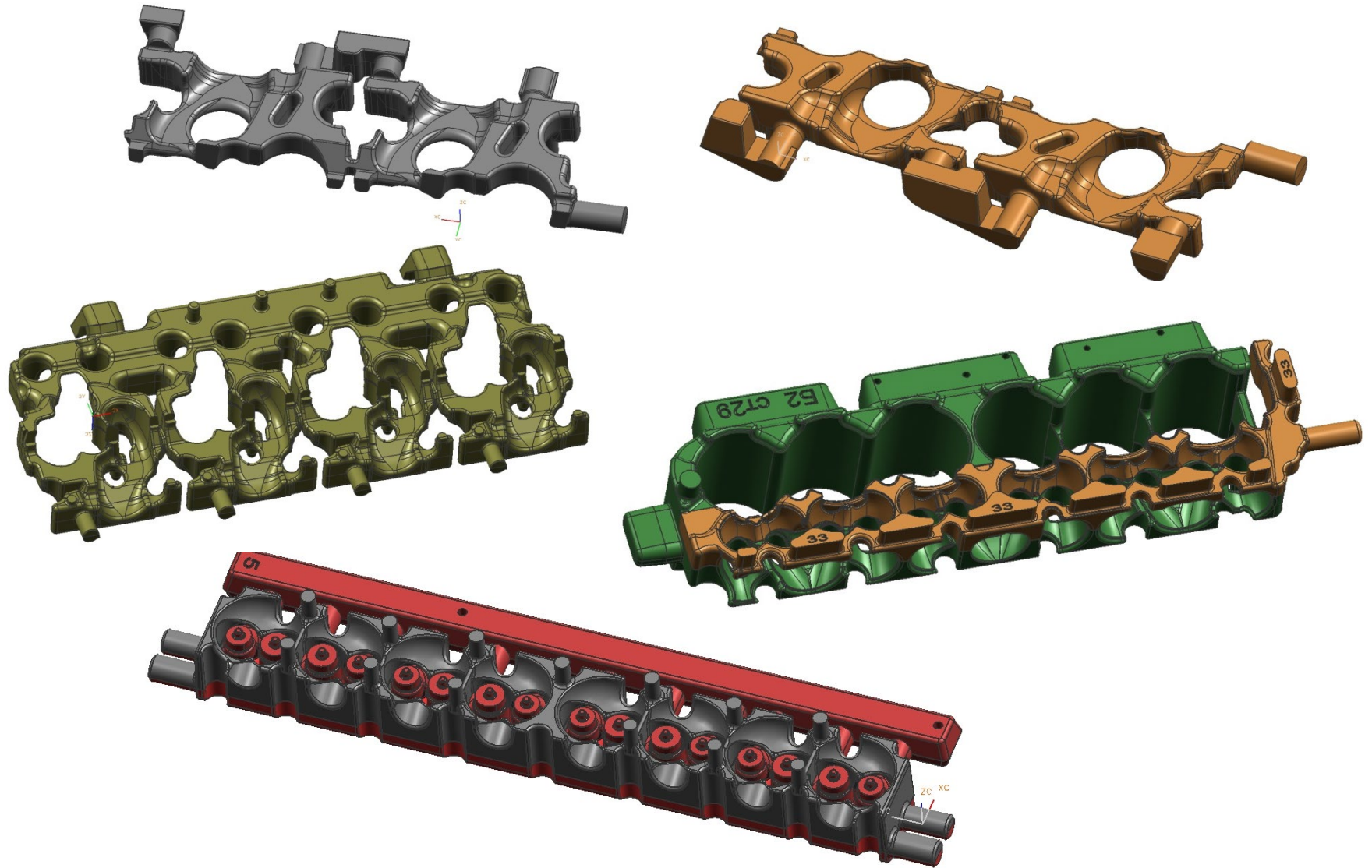

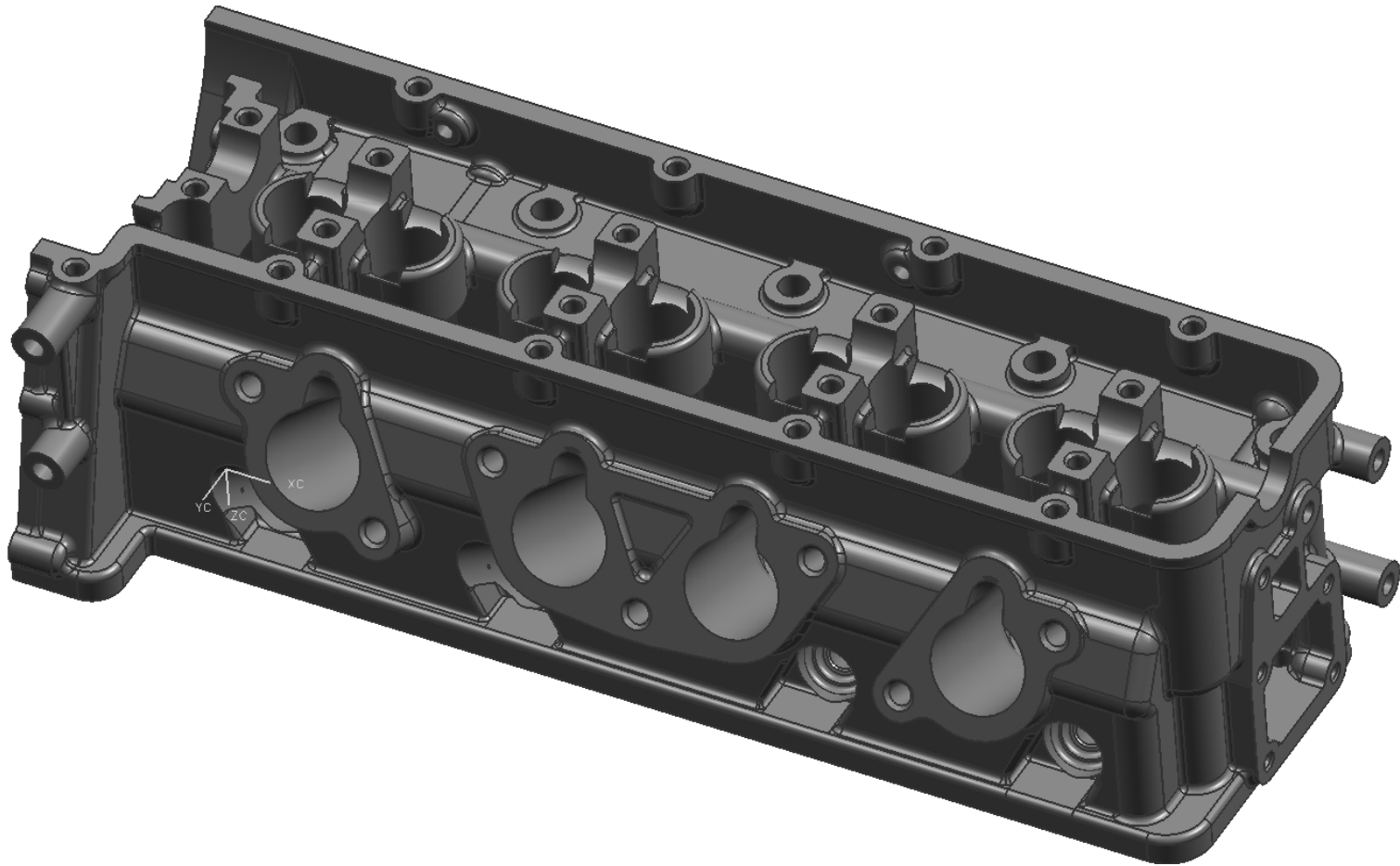

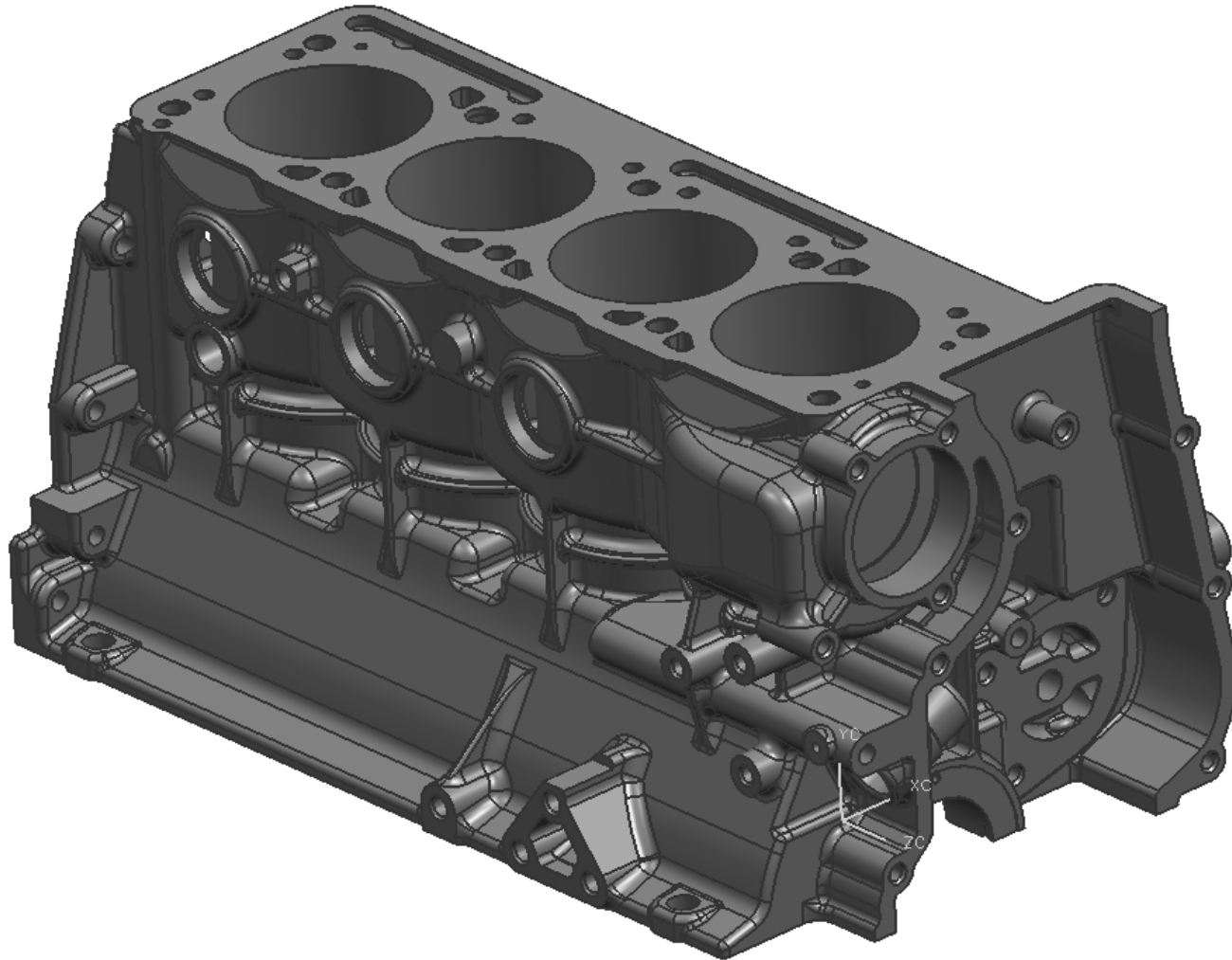



OPTIMIZATION OF THE PART DESIGN BASED ON ADDITIVE TECHNOLOGIES

TRADITIONAL DESIGN

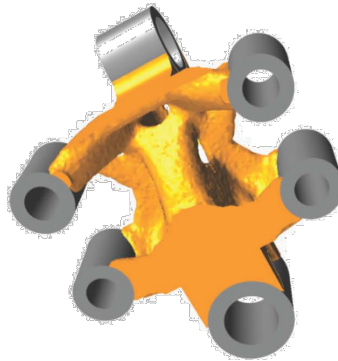
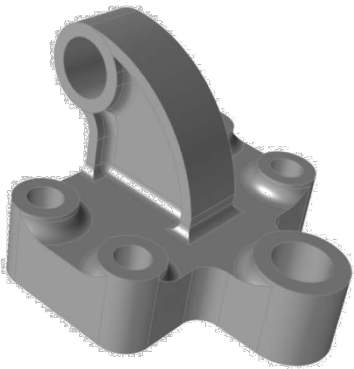

OPTIMIZED IN WEIGHT
AND GEOMETRY DESIGN

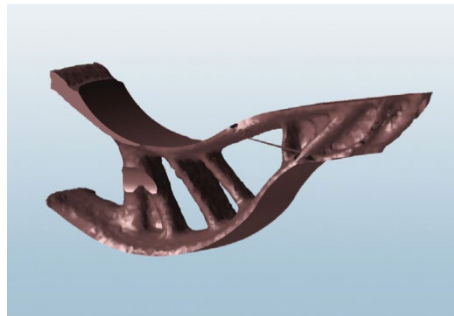
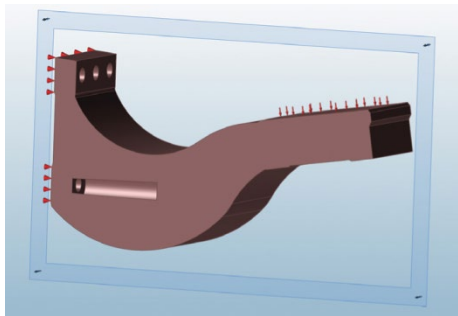



COMPOSITE PARTS

LATHE



PART



3D PRINT

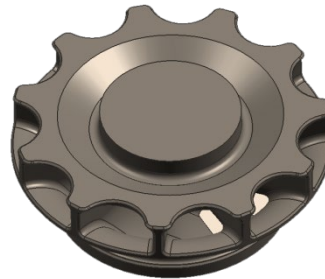



EQUIPMENT FOR 3D-PRINTING

- POLYMER POWDER MATERIALS
- METAL POWDERS
- QUARTZ SAND
- CERAMIC POWDER MATERIALS





COMPLEX «SAND CASTING MOLDS»

TECHNOLOGICAL COMPLEX ADDITIVE MANUFACTURE OF SAND MOLDS AND CORES

DIGITAL DATA

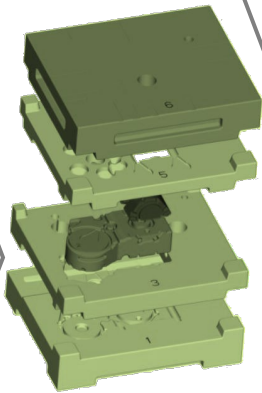

**CAD
OF SAND CASTING
MOLD**

EQUIPMENT FOR ADDITIVE MANUFACTURING



PRODUCTS

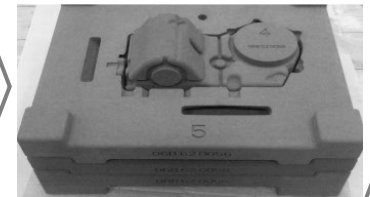



PERFORMANCE COMPARISON OF THE EQUIPMENT FOR 3D- PRINTED MOLDS



S-15 (2008 year)

Number of job boxes: 1
Build volume: 1500 x 750x 700 mm
Build speed: 13-27 L/h
Operating time per job box: 44 h
Sand consumption for full box: 1,2 t



Exerial (2015 year)

Number of job boxes: 2
Build volume: 2200 x 1200 x 700 mm
Build speed: 300-400 L/h
Operating time per job box: 12 h
Sand consumption for full box: 12 t



	S-Print			S-Max	S-Max+		Exerial	
	Furan	Phenol	Silicate	Furan	Phenol	Silicate	Furan	Silicate
Build volume	800 x 500 x 400 мм			1800 x 1000 x 700 мм	1800 x 1000 x 600 мм		2200 x 1200 x 700 мм	
Job box capacity	160 л			1,260 л	1,080 л		3,696 л	
Build speed	20-36 л/ч	16-36 л/ч	16-18 л/ч	60-85 л/ч	60-85 л/ч	65-85 л/ч	300-400 л/ч	300-320 л/ч
Layer thickness	280-500 мкм	240 мкм	280-340 мкм	280-500 мкм	280-500 мкм	280-380 мкм	380-500 мкм	280-380 мкм
Print resolution	X/Y/Z 100 мкм			X/Y/Z 100 мкм	X/Y/Z 100 мкм	X/Y/Z 100 мкм	X/Y/Z 100 мкм	X/Y/Z 100 мкм
External dimensions	3270 x 2540 x 2860 мм			6900 x 3520 x 2860 мм	3860 x 2890 x 3470 мм		.8380 x 4030 x 4950 мм	
Weight	3,500 кг			6500 кг	5,800 кг		12,000 кг	
Electrical requirements (equipment)	400 В / 3 ~/N/PE/50-60 Гц макс. 6,2 кВт			400 В / 3 ~/N/PE/50-60 Гц макс. 6,3 кВт	400 В / 3 ~/N/PE/50-60 Гц макс. 6,2 кВт		400 В / 3 ~/N/PE/50-60 Гц макс. 21,5 кВт	
Electrical requirements (heater)	400 В / 3 ~/PE/50-60 Гц макс. 6,3 кВт			400 В / 3 ~/PE/50-60 Гц макс. 10,5 кВт	400 В / 3 ~/PE/50-60 Гц макс. 19,2 кВт		400 В / 3 ~/PE/50-60 Гц макс. 12,6 кВт	
Data interface	STL			STL	x1c, x1i		x1c, x1i	



THE AUTOMATED AREA OF FORMS AND CORES COMPONENTS PRODUCTION

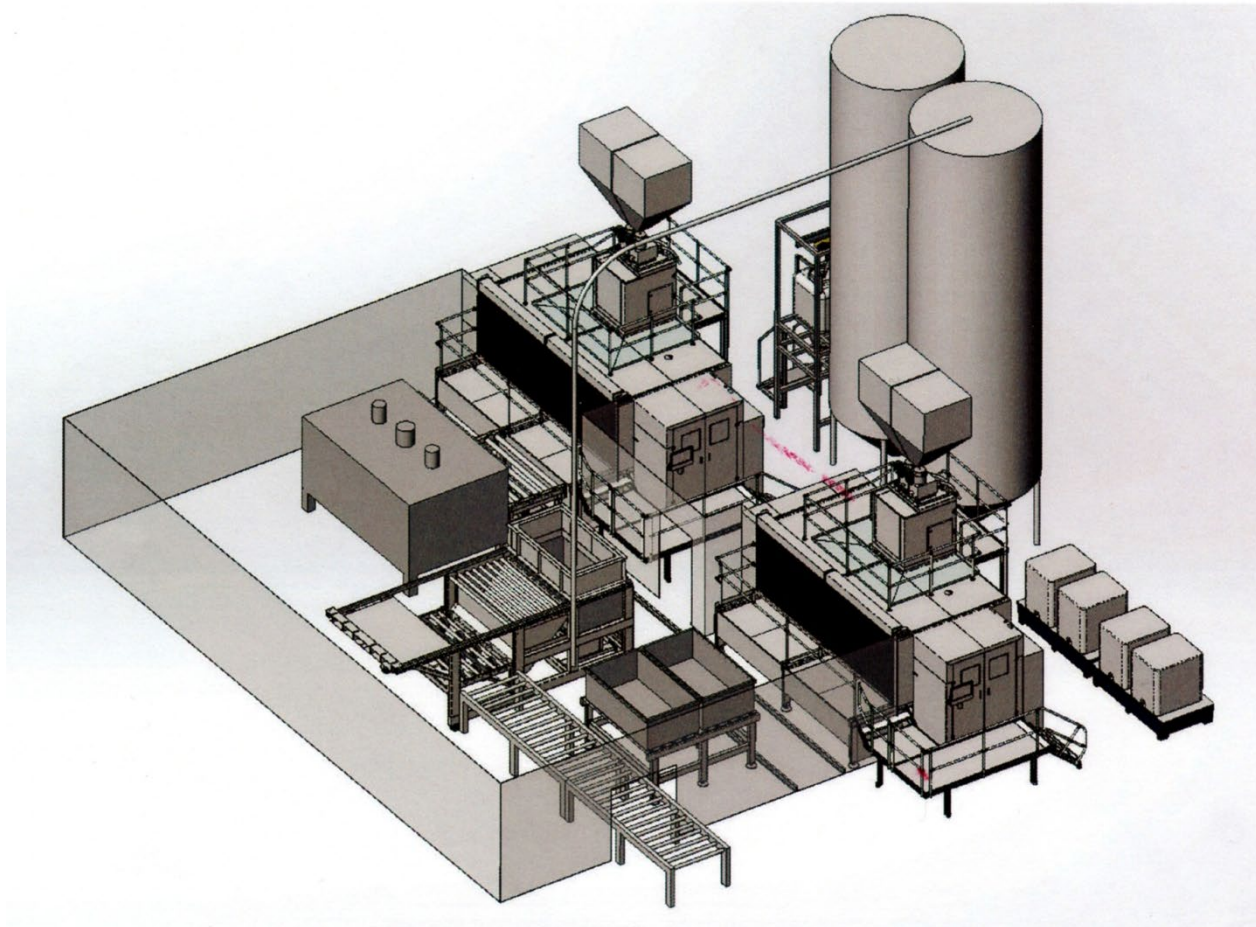



CASTING MOLDS

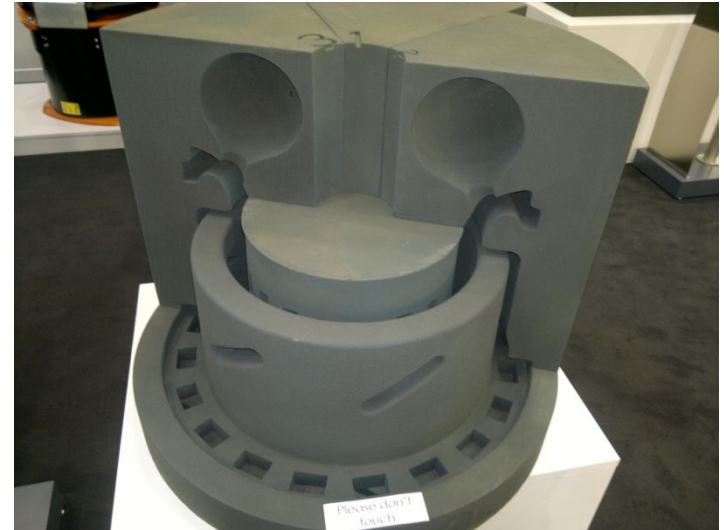
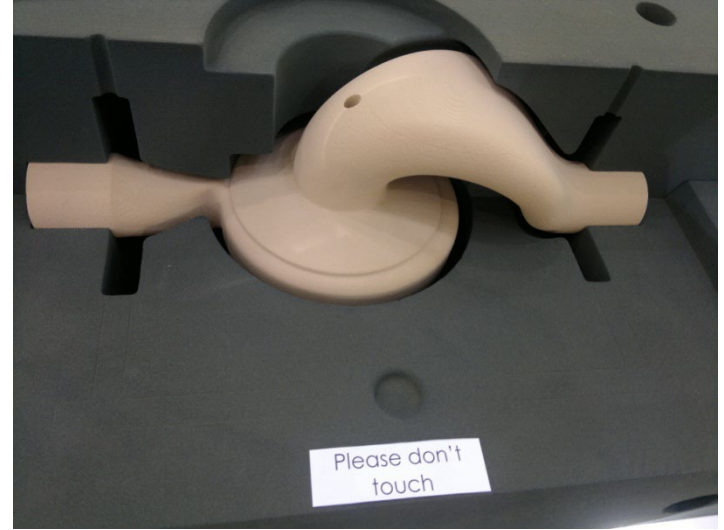



EXAMPLES OF COMPLETED ORDERS

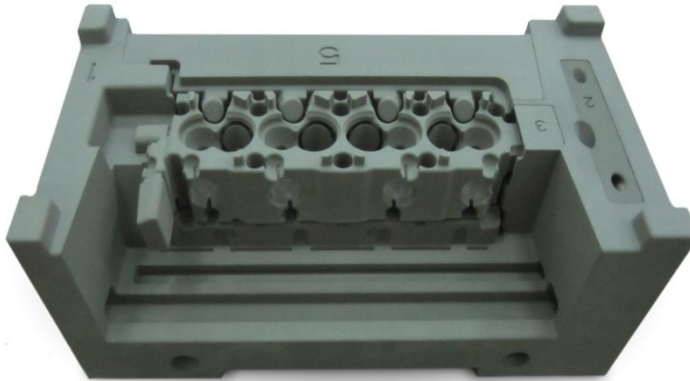
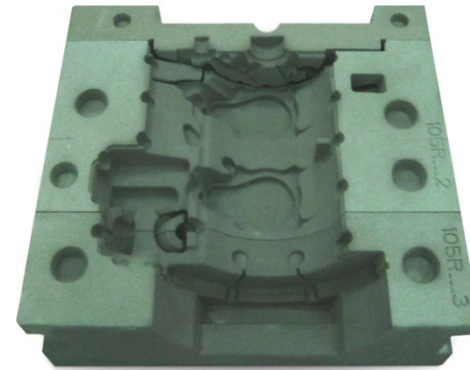
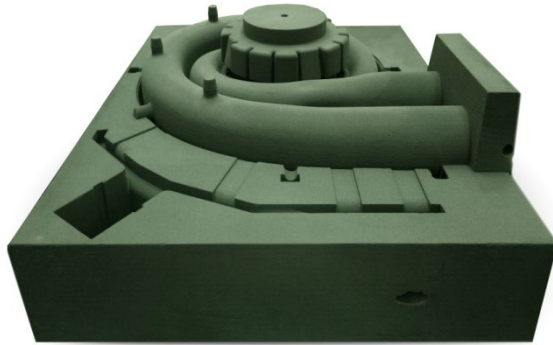



COMPLEX «COMPOSITE METALS»

TECHNOLOGICAL COMPLEX ADDITIVE MANUFACTURING OF PARTS
FROM COMPOSITE METALS

DIGITAL DATA

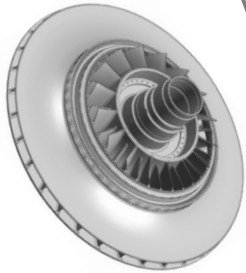

CAD
COMPOSITE PART

EQUIPMENT FOR ADDITIVE MANUFACTURING



PRODUCTS





PARTS OF COMPOSITE METALS

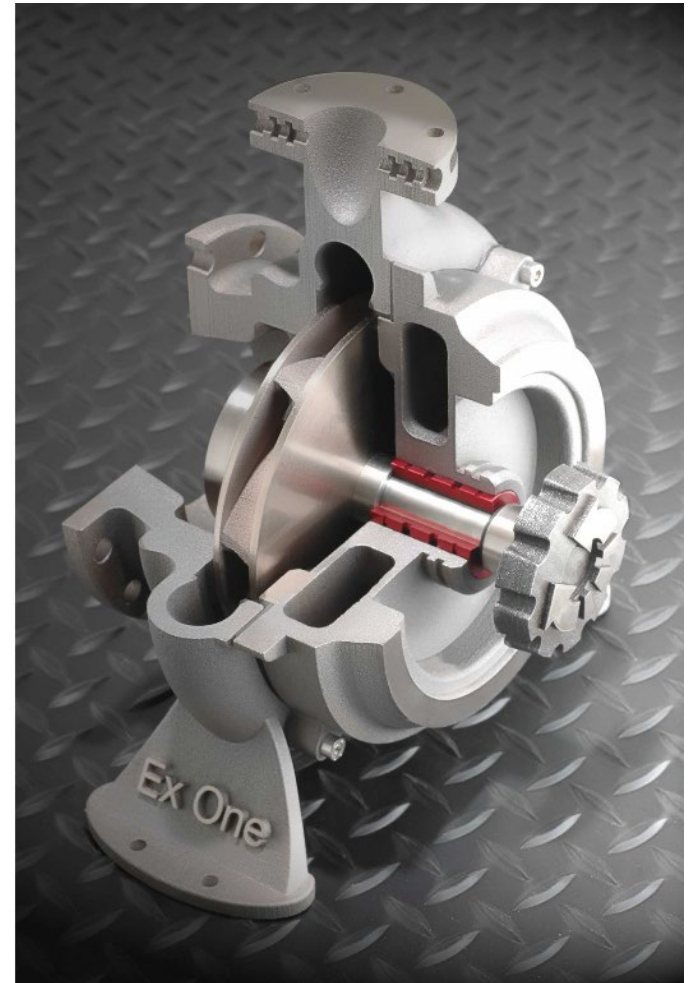
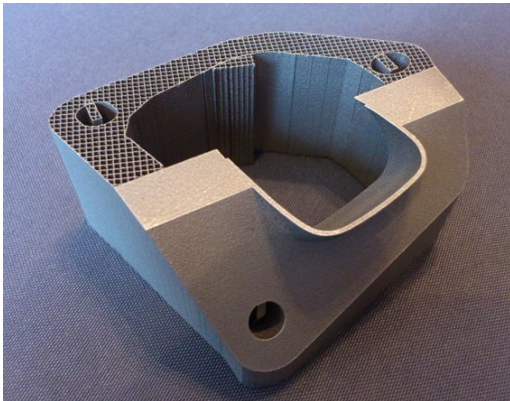



3D-PRINTING FROM METAL POWDERS

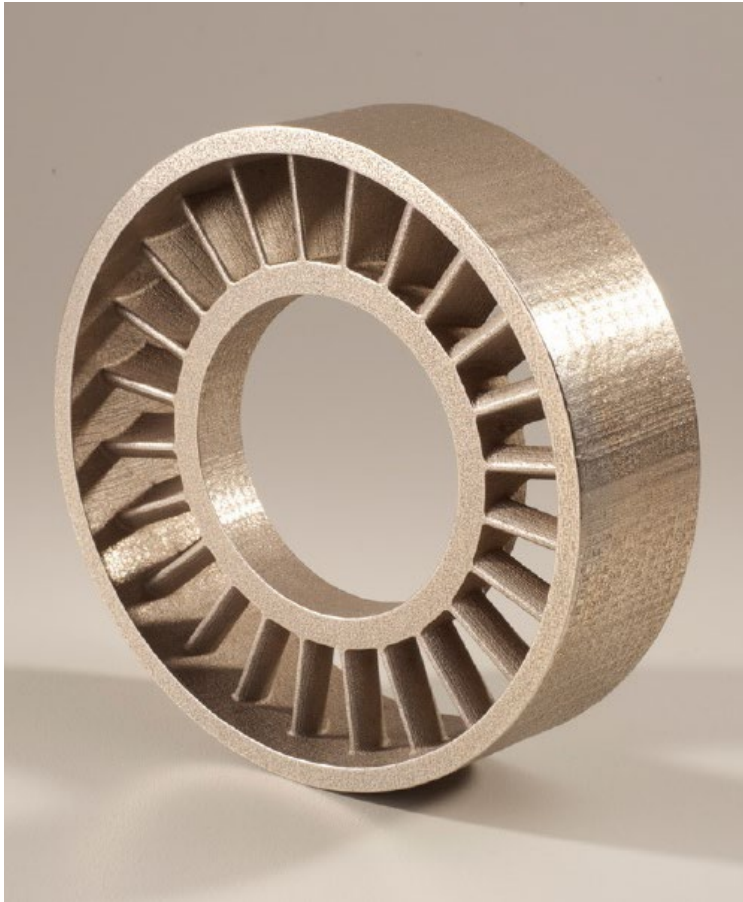

Traditional technology
Wear after 300 hours.



Additive technology
Wear after 600 hours.





3D-PRINTING FROM METAL POWDERS





M-Print



M-Flex



Innovent

	M-Print	M-Flex	Innovent
Build volume	800 x 500 x 400 мм	400 x 250 x 250 мм	160 x 65 x 65 мм
Job box capacity	160 л	25 л	0,1 л
Build speed	60 секунд/слой 20-36 л/ч	30-60 секунд/слой	30-60 секунд/слой
Layer thickness	150 мкм	100 мкм	100 мкм
Print resolution	X/Y 63,5 мкм Z 150 мкм	X/Y 63,5 мкм Z 100 мкм	X/Y 63,5 мкм Z 100 мкм
External dimensions	3270 x 2540 x 2860 мм	1675 x 1400 x 1855 мм	1203 x 887 x 1434 мм
Weight	3,500 кг	1020 кг	320 кг
Electrical requirements	208-240 В / 3 ~	208-240 В / 3 ~	120 В / 1 ~ /60 Гц 230 В / 1 ~ /50 Гц
Data interface	SLC, CLI, STL	SLC, CLI, STL	SLC, CLI, STL



COMPLEX «BURN-OUT CASTING MODELS»

TECHNOLOGICAL COMPLEX ADDITIVE MANUFACTURING OF BURN-OUT CASTING MODELS

DIGITAL DATA

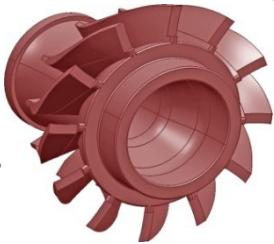

CAD
BURN-OUT
CASTING MODEL

EQUIPMENT FOR ADDITIVE MANUFACTURING



PRODUCTS





			
	VX 1000	M-Flex	Innovent
Build volume	1000 x 600 x 500 мм	500 x 400 x 300 мм	300 x 200 x 150 мм
Job box capacity	300 л	60 л	9 л
Build speed	36 мм/ч	15 мм/ч	12 мм/ч
Layer thickness	100/300 мкм	80/150 мкм	150 мкм
Print resolution	до 600 dpi	до 600 dpi	До 300 dpi
External dimensions	2800 x 2400 x 2300 мм	1750 x 1850 x 2100 мм	1700 x 900 x 1500 мм
Weight	3,500 кг	1200 кг	450 кг
Electrical requirements	208-240 В / 3 ~	208-240 В / 3 ~	120 В / 1 ~ /60 Гц 230 В / 1 ~ /50 Гц
Data interface	STL	STL	STL



BURN-OUT CASTING MODELS FOR PRECISION CASTING

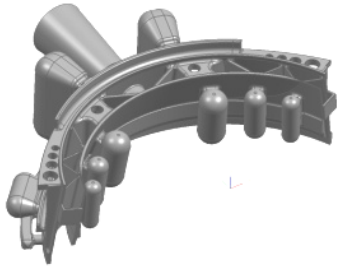

Dimensions :
510 x 370 x 180 mm
Build volume :
3600000 mm³

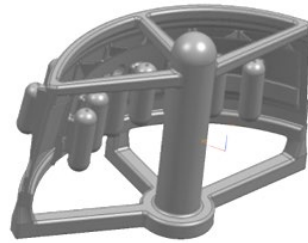

Dimensions :
455 x 270 x 280 mm
Build volume :
3130000 mm³

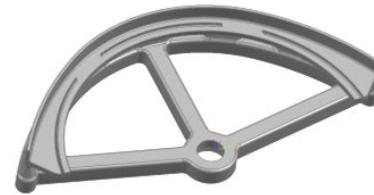

Dimensions :
580 x 290 x 87 mm
Build volume :
1784900 mm³



Dimensions :
280 x 87 x 65 mm
Build volume :
407600 mm³

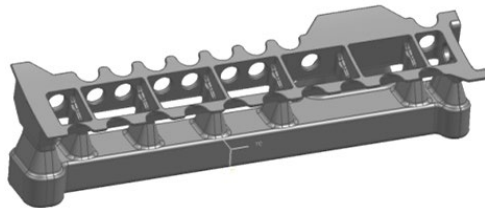

Dimensions :
410 x 117 x 100 mm
Build volume :
927000 mm³



Dimensions :
540 x 90 x 95 mm
Build volume :
774100 mm³



Dimensions :
470 x 140 x 130 mm
Build volume :
1021000 mm³



EXAMPLES OF COMPLETED ORDERS

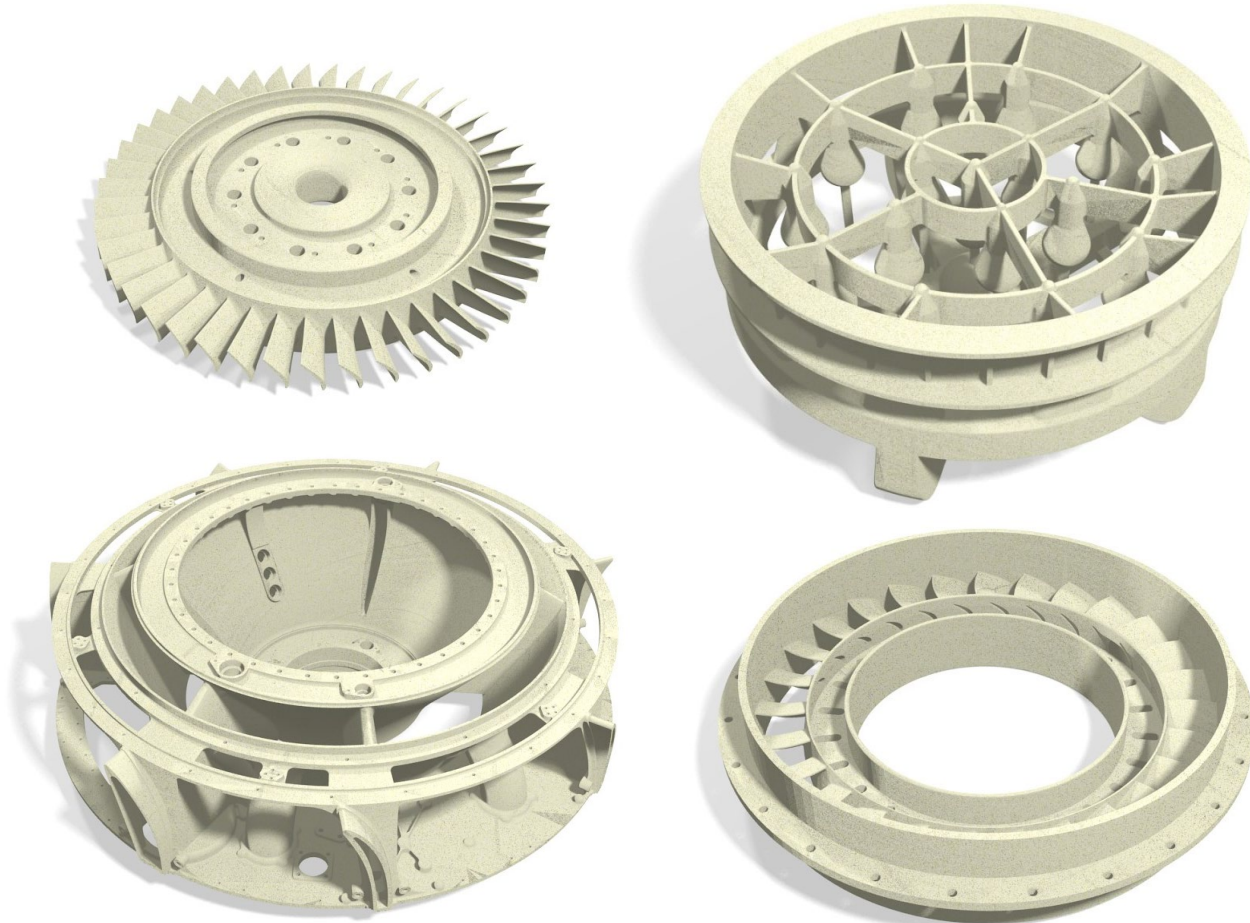



EQUIPMENT FOR
SELECTIVE LASER MELTING

- POLYMER POWDER MATERIALS
- METAL POWDERS





COMPLEX «LASER SYNTHESIS»

TECHNOLOGICAL COMPLEX ADDITIVE MANUFACTURE OF METAL PARTS

DIGITAL DATA

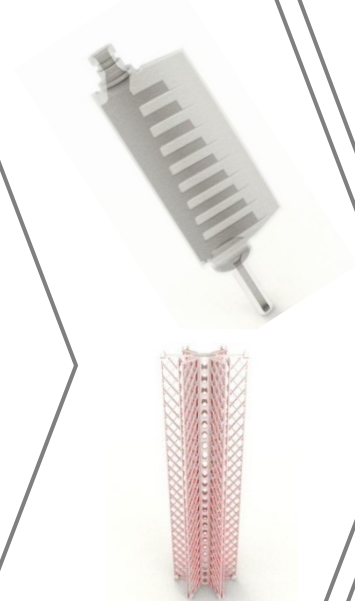

CAD
METAL PART

EQUIPMENT FOR ADDITIVE MANUFACTURE



PRODUCTS





SLM
SOLUTIONS

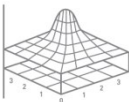

SLM 500

SLM 250

SLM 125

Build Envelope:	500 x 280 x 325 мм	280 x 280 x 350 мм	125 x 125 x 75 (125) мм
3D Optics Configuration:	4 x 400 Вт или 2 x (400 Вт +1000 Вт) Yb-волоконный	400/1000 Вт YLR	100/200 Вт YLR
Build Rate (max):	70-180 см ³ /ч	20/35 см ³ /ч	15 см ³ /ч
Variable Layer Thickness:	20 - 200 мкм	20 – 75 мкм/100 мкм	20 - 40 мкм
Min. Feature Size:	160 - 180 мкм	150 мкм/1000 мкм	140 - 160 мкм
Beam Focus Diameter:	80-150 мкм (400 Вт) или 700 мкм (1000 Вт)	70-120 мкм/700 мкм	70-130 мкм
Max. Scan Speed:	15 м/с	15 м/с	20 м/с
Average Inert Gas Consumption in Process:	Ar/N ₂ , 5 л/мин	Ar/N ₂ , 2,5 л/мин	Ar/N ₂ , 0,5 л/мин
Average Inert Gas Consumption Purging:	Ar/N ₂ , 2500 л @ 100 л/мин	Ar/N ₂ , 1700 л @ 100 л/мин	Ar/N ₂ , 1000 л @ 100 л/мин
Compressed Air Requirement / Consumption:	ИСО 8573-1, 30 л/мин @ 1,5 барр	ИСО 8573-1, 18 л/мин @ 1,5 барр	ИСО 8573-1, 12,5 л/мин @ 1,5 барр
Dimensions (L x W x H):	3000 x 2000 (2500) x 1100 мм	1800 x 1900 (2400) x 1000 мм	1350 x 1900 (2400) x 800 мм
Weight :	около 2000 кг	около 1000 кг	около 700 кг
Electrical requirements:	400 В / 3NPE, 32 А, 50/60 Гц, 8 кВт/ч	400 В / 3NPE, 32 А, 50/60 Гц, 8 кВт/ч	400 В / 3NPE, 32 А, 50/60 Гц, 4 кВт/ч

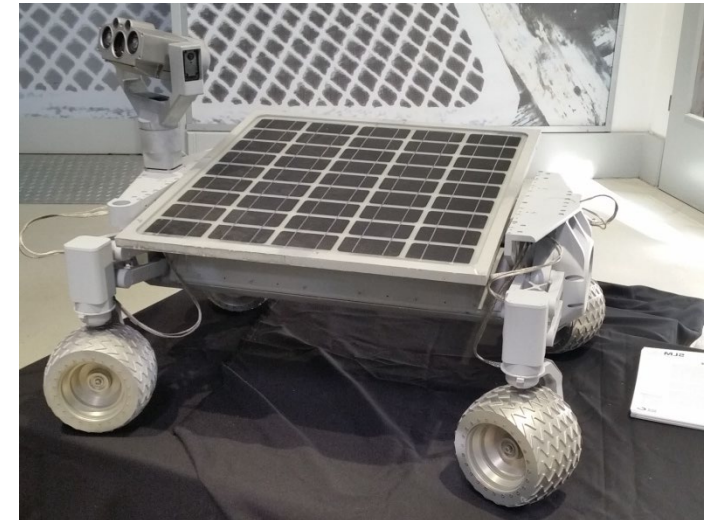
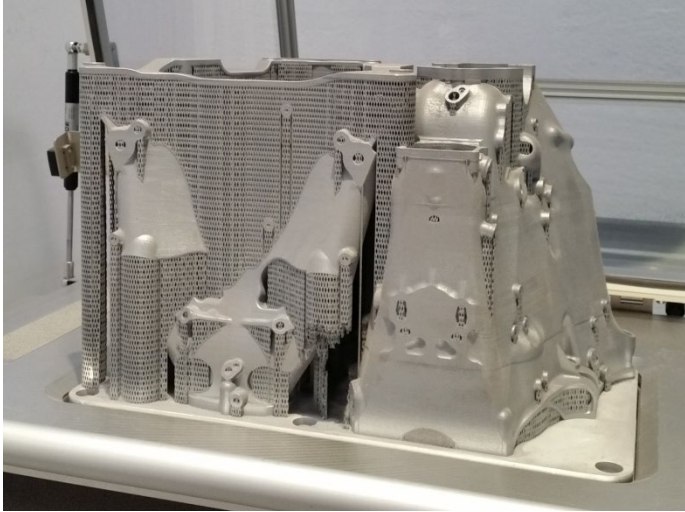

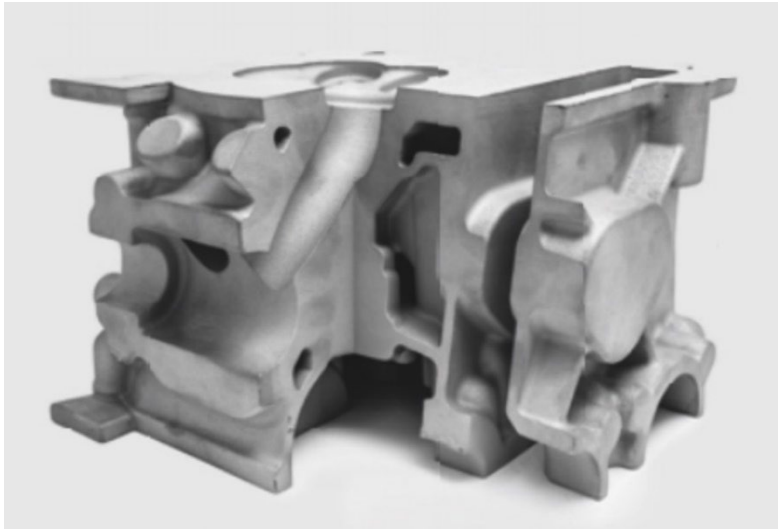
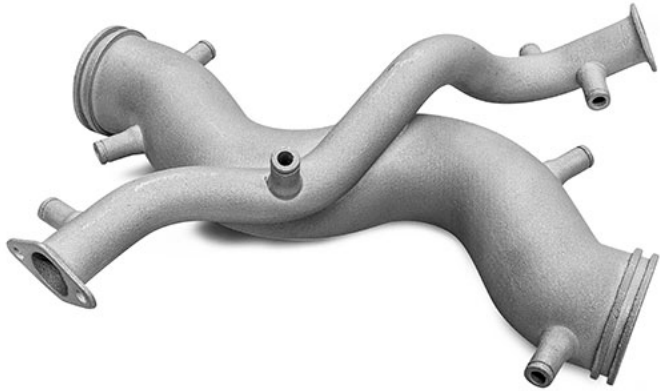

Weight : 5,1 kg
Functional surface : 823 cm²

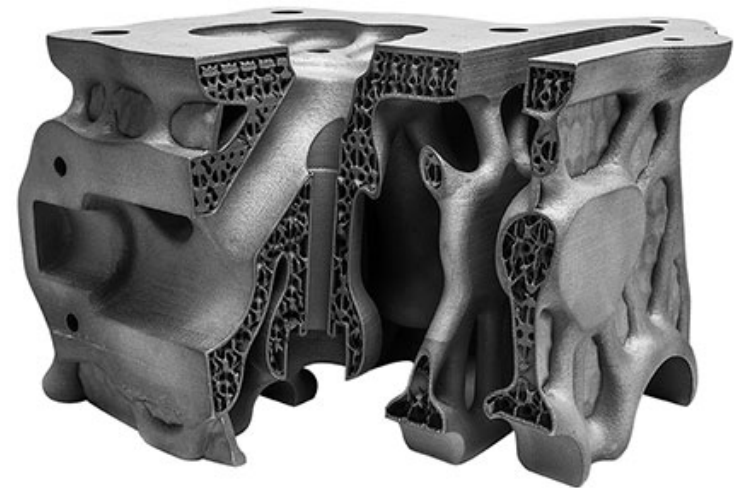

Weight : 1,9 kg
Functional surface : 10 223 cm²

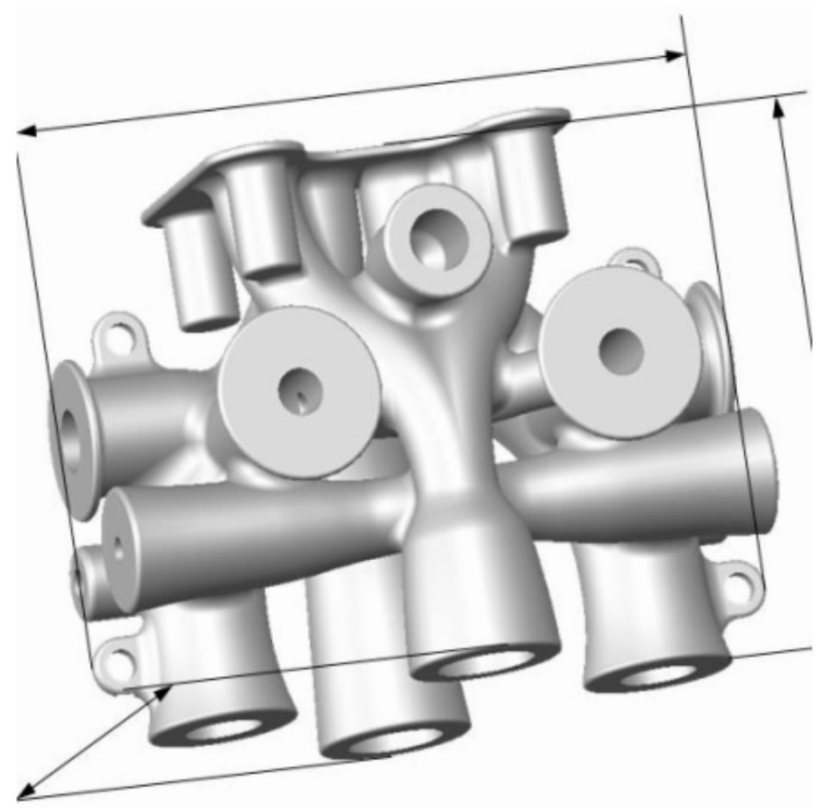
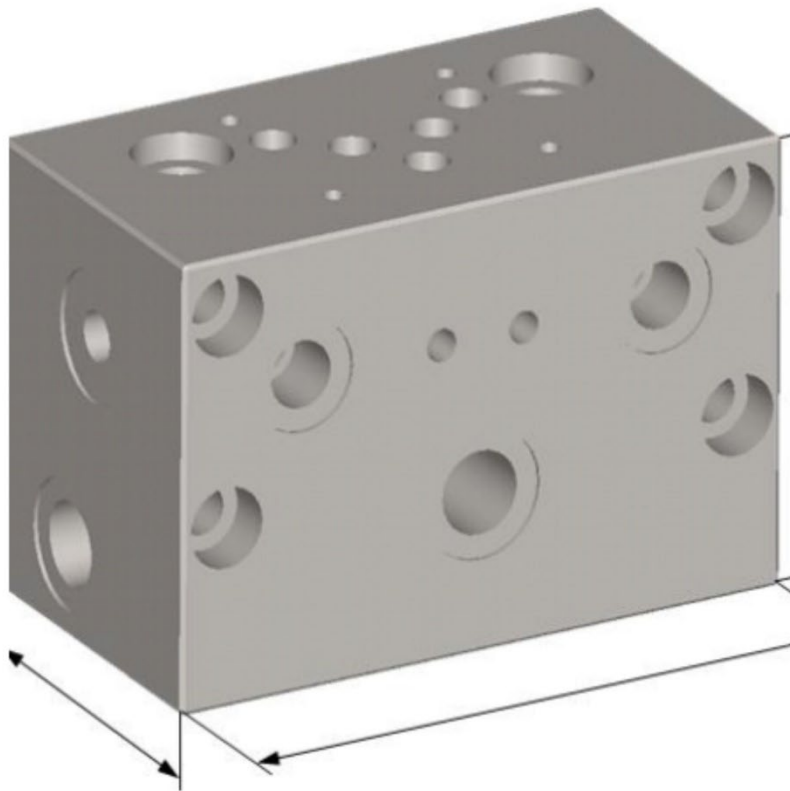



RESEARCH
INDUSTRIAL
COMPLEX
DIGITAL CASTING PRODUCTION

DIGITAL
ADDITIVE
MANUFACTURING



ULTRASONIC TECHNOLOGY

- CASTING TECHNOLOGY
- INTENSIFICATION OF PROCESSES
- CONTROL



ANYTHING
HAS IT'S
OWN
SOUND



CONTINUOUS ULTRASONIC PROCESSING APPLIED TO ALLOY

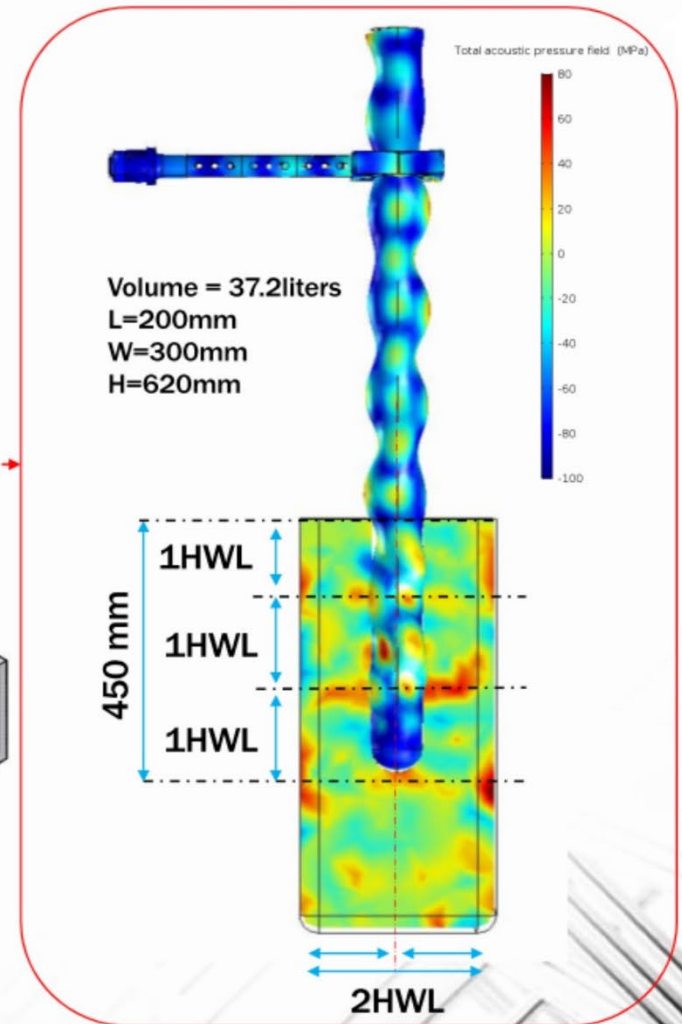
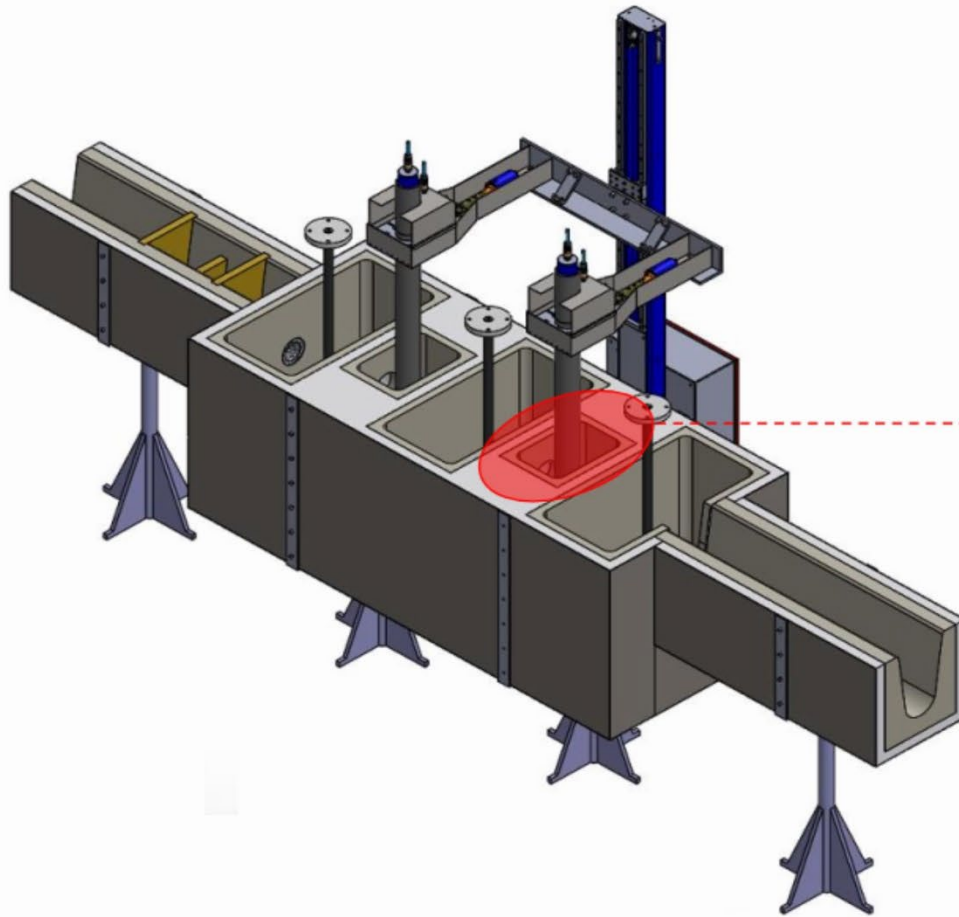



DESIGN OPTIONS APPLIED IN PROCESSING OF LIGHT ALLOY MELTS

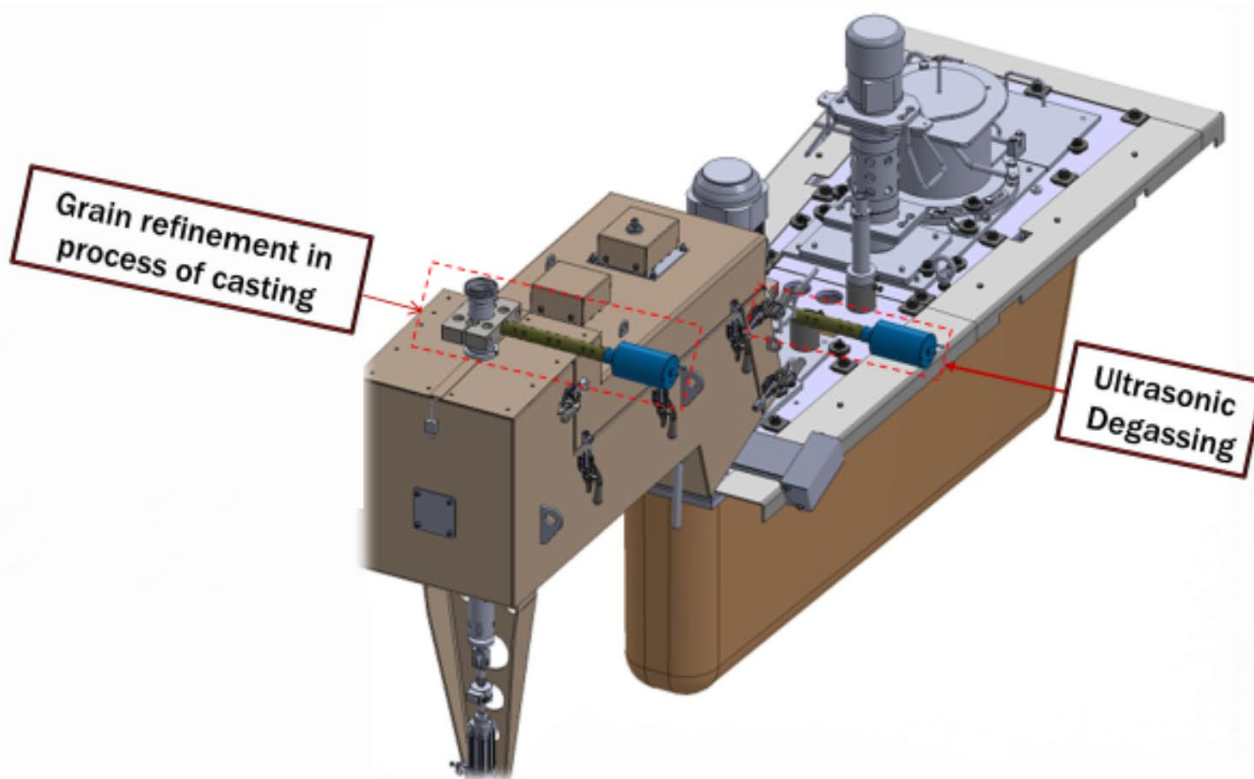

Light Alloys Furnace
Ultrasonically optimized

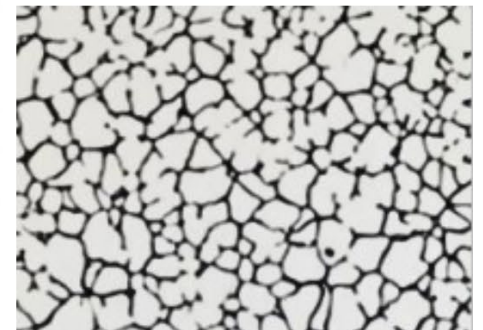



DEGASSING AND MODIFICATION OF ALLOY

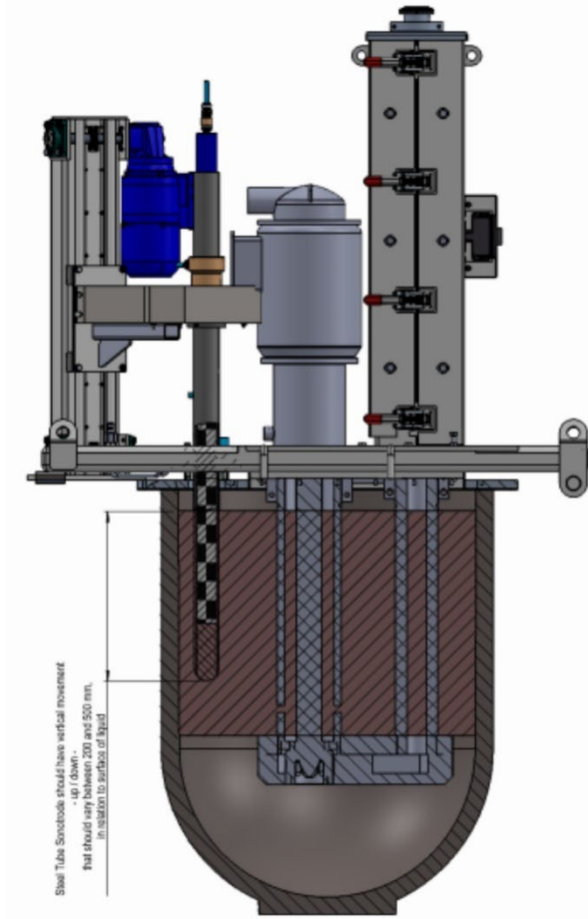

freq(1)=19800 Slice: Total acoustic pressure field (MPa)

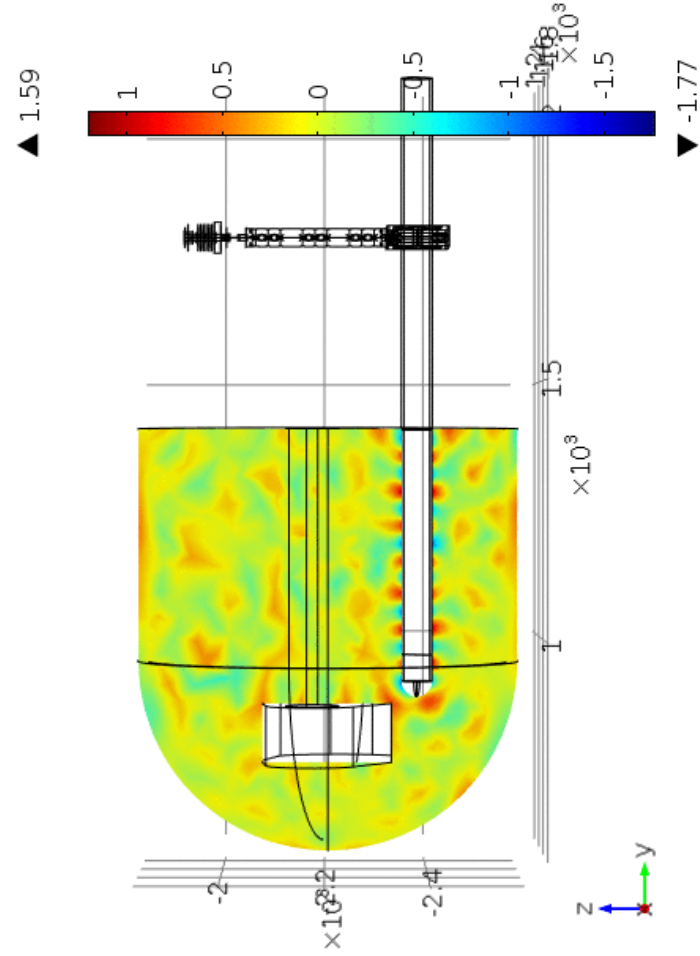



ALLOY MODIFICATION

Static Casting, Ultrasonically Assisted

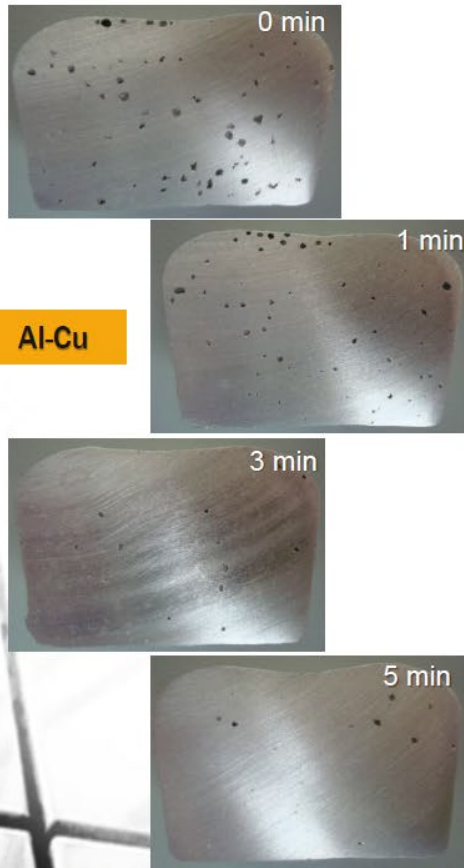

Some of our experimental results

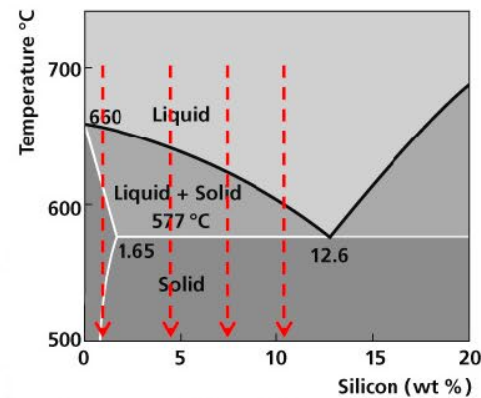
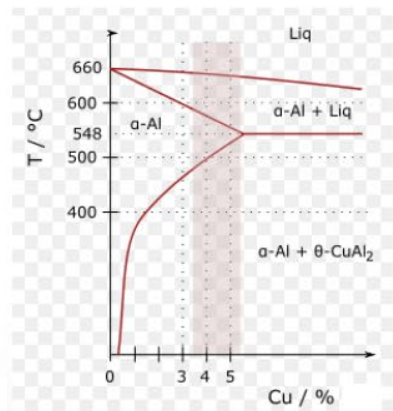
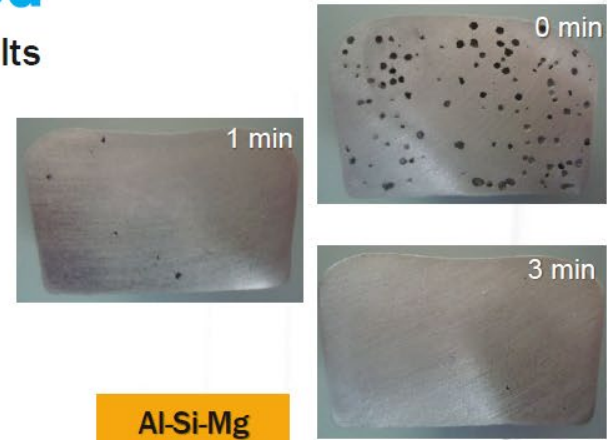
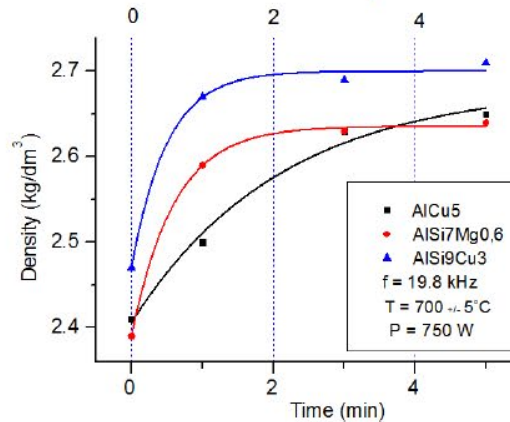



ALLOY MODIFICATION

AlSc

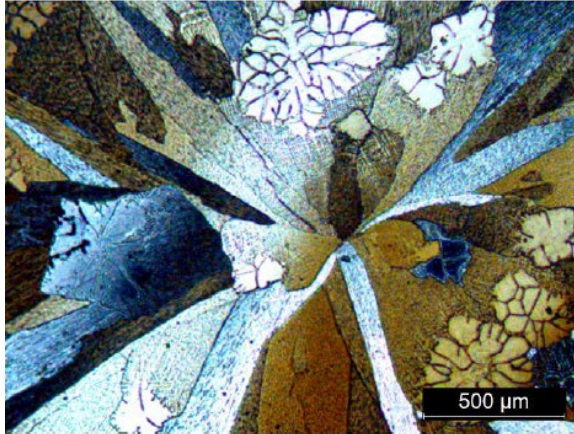

AlSc+US

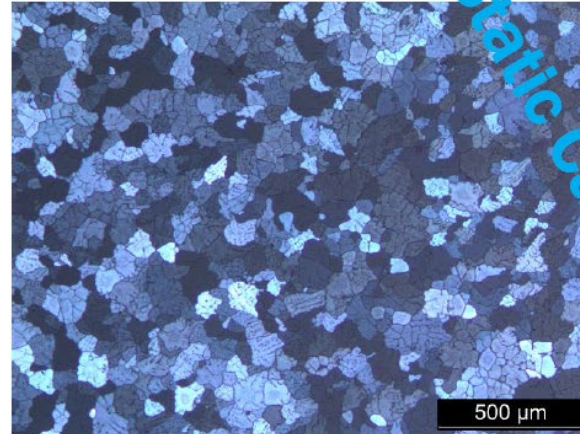

Static Casting

AlScMg

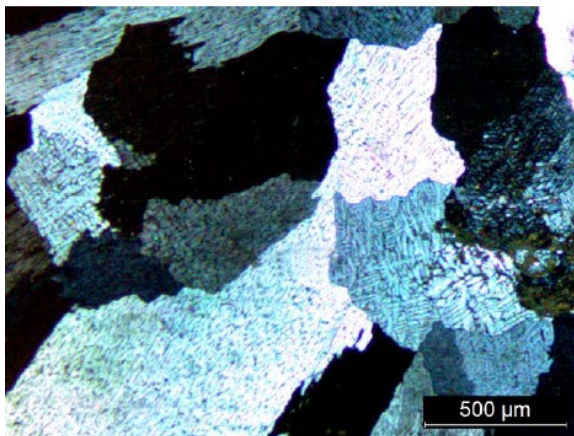

AlScMg+US

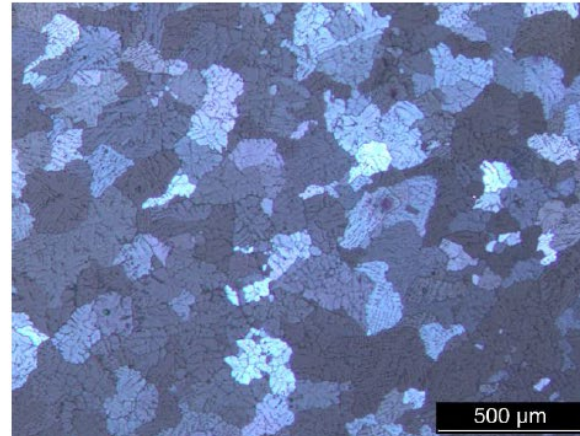



GEARBOX HOUSING CASTING WITH AN APPLICATION OF MMM TECHNOLOGY

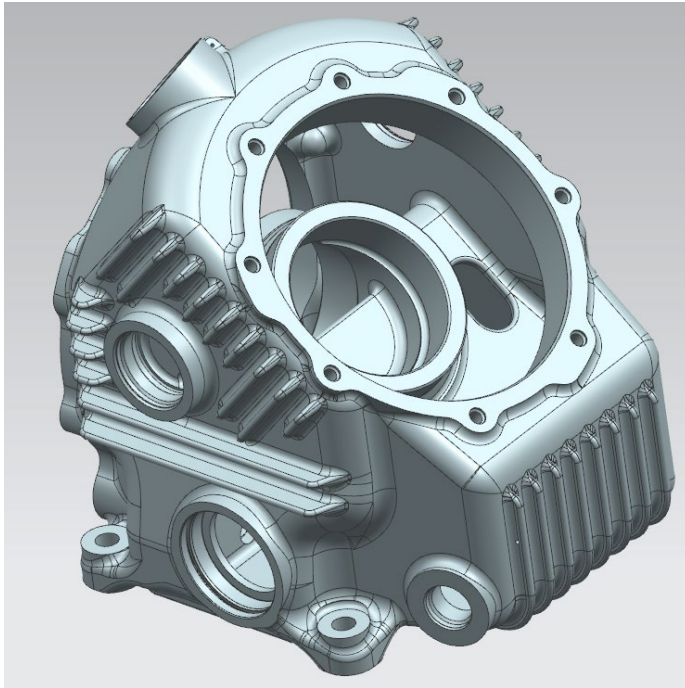

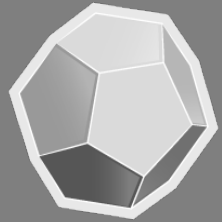

EQUIPMENT FOR
PRECISION CASTING

- NON-FERROUS METALS
- FERROUS METALS

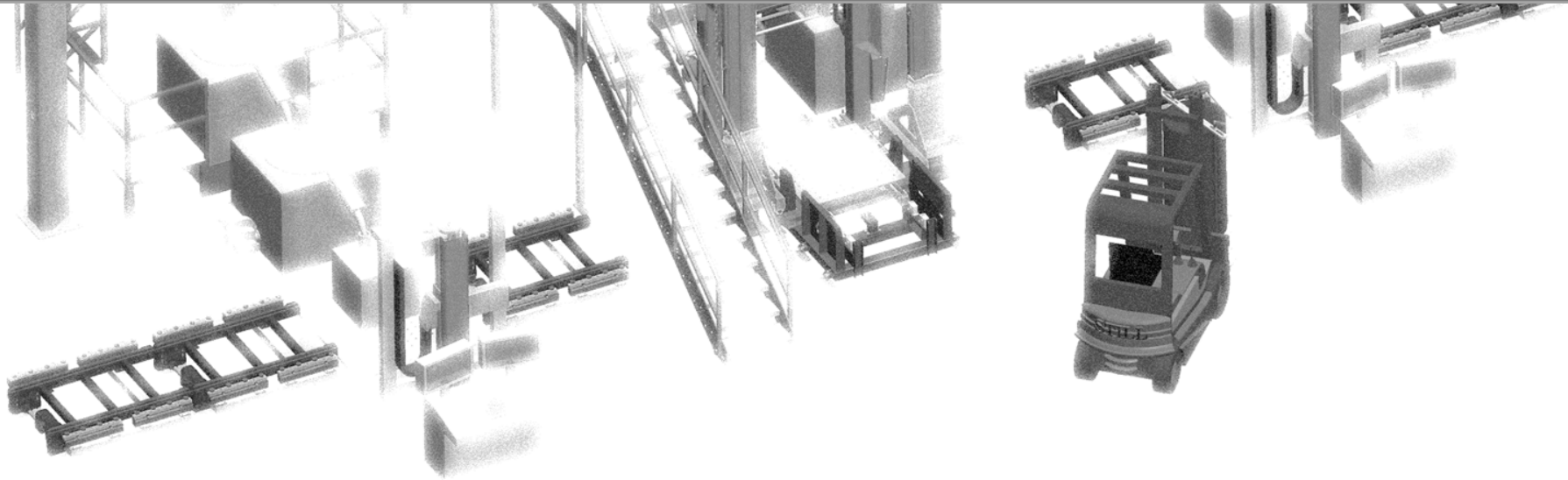



COMPLEX «ALLOY PREPARATION»

TECHNOLOGICAL COMPLEX PREPARATION OF ALLOY WITH SPECIAL PROPERTIES
TO ENSURE HIGH-QUALITY CASTING

ALLOY

ORIGINAL
MAGNESIUM
CHARGE ALLOY

WASTE GATING
SYSTEMS

CHIPS

COMPLEX FOR ALLOY PREPARATION



PRODUCTS

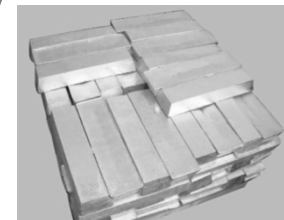
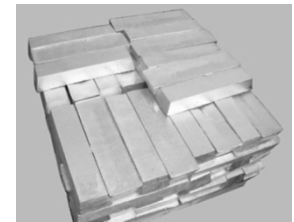
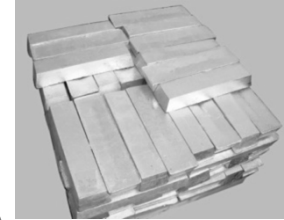



CHIP CONVERTER

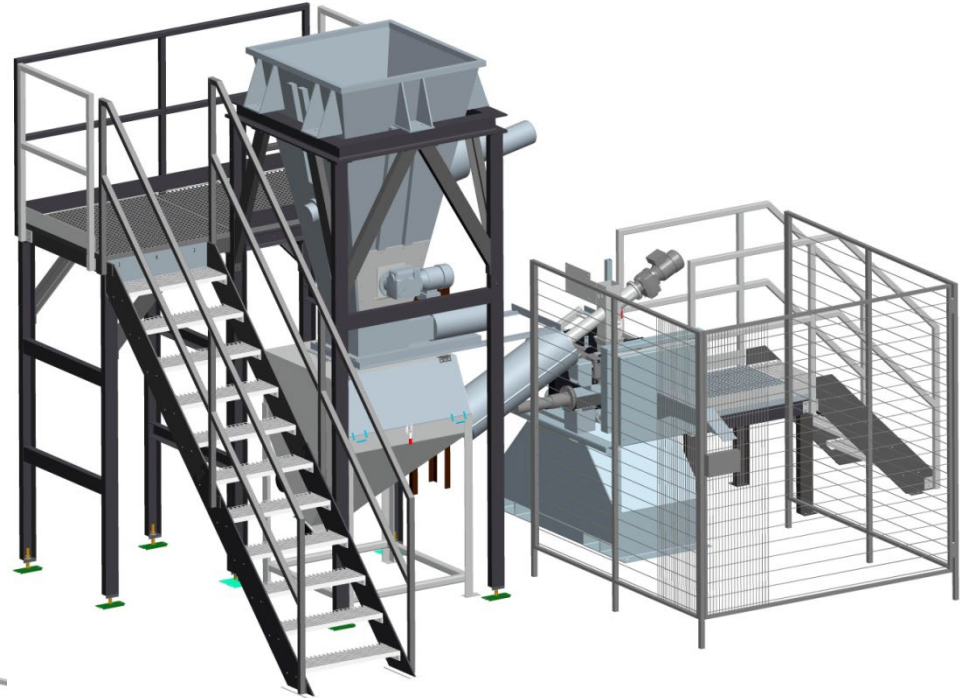
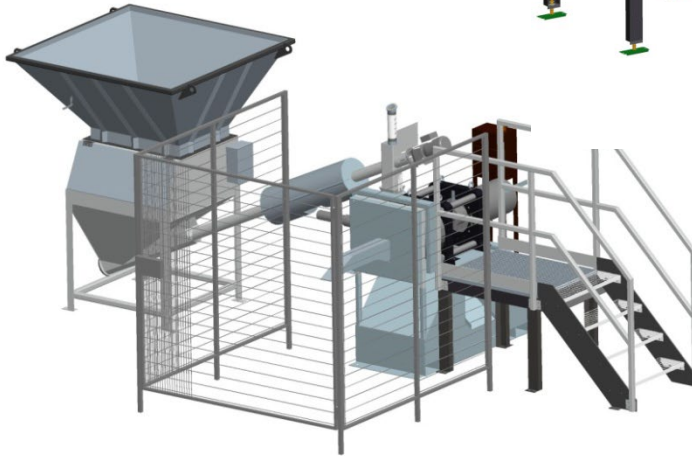
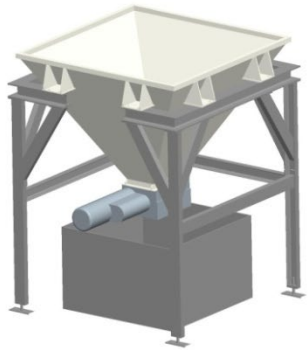



COMPLEX «CASTING OF NON-FERROUS METALS»

SYSTEMS FOR MAGNESIUM AND ALUMINUM LOW PRESSURE CASTING AND GRAVITY CASTING
WITH DOSING OF METAL

EQUIPMENT



CASTING COMPLEX

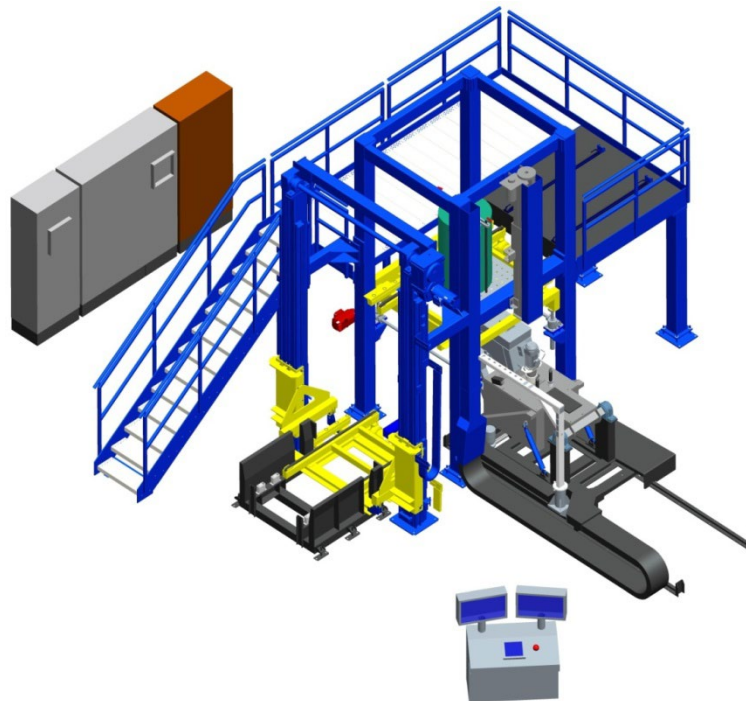

PRODUCTS

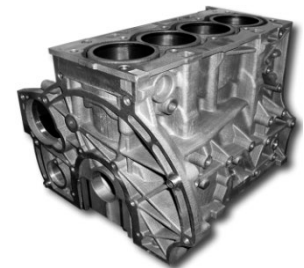



LOW PRESSURE CASTING SYSTEM





AREA LAYOUT OF LOW PRESSURE CASTING SYSTEM FOR MAGNESIUM AND ALUMINUM ALLOYS

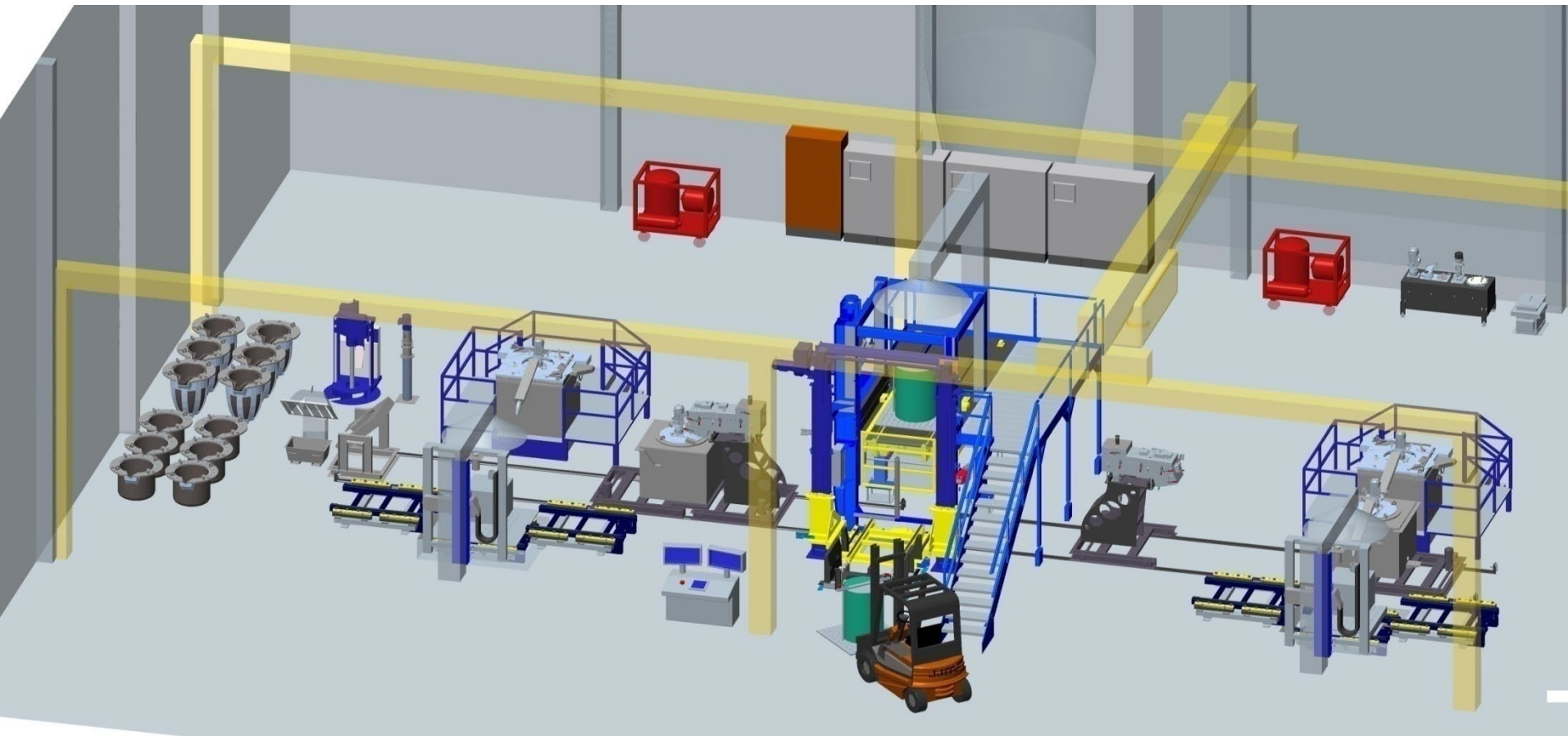



DOSED GRAVITY CASTING





FURNACE FOR DOSED GRAVITY CASTING

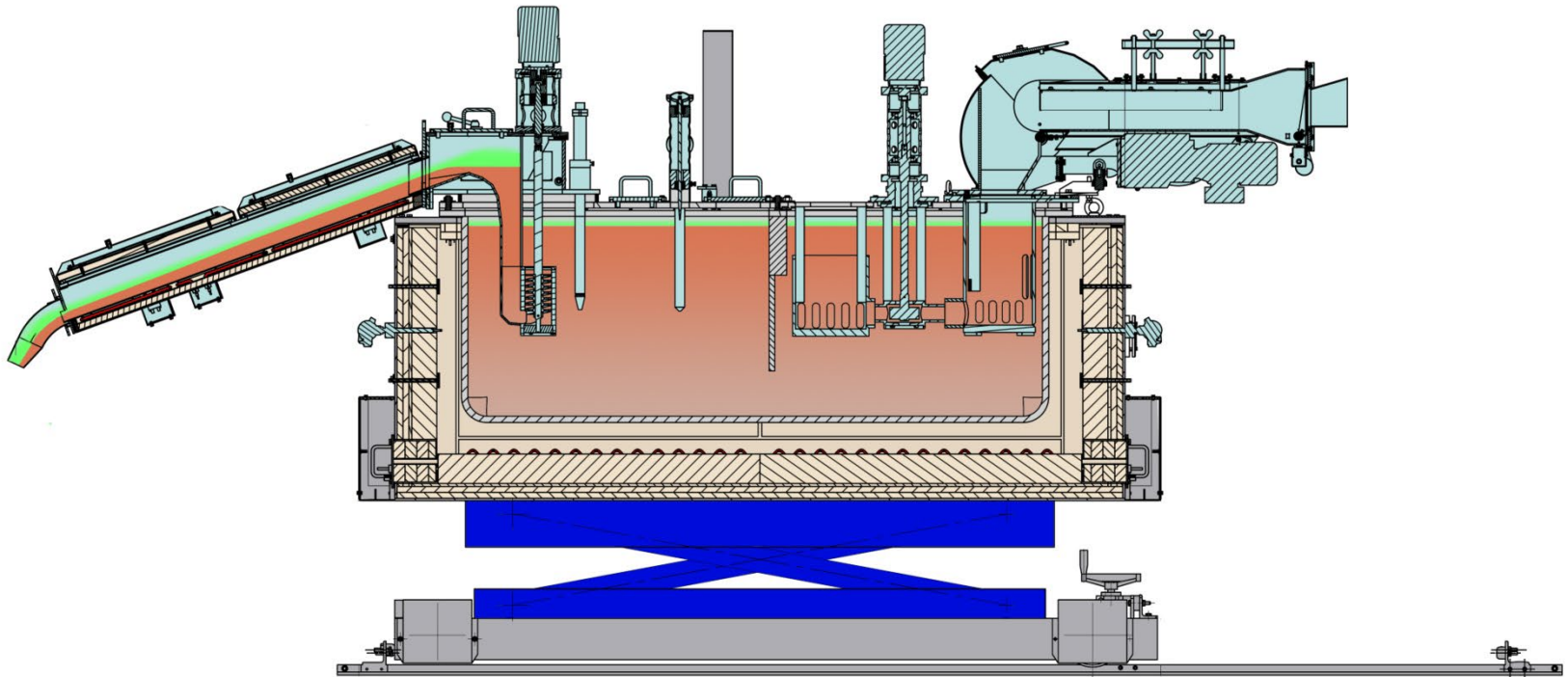



TECHNOLOGICAL COMPLEX OF ALLOY PREPARATION AND DOSED GRAVITY CASTING

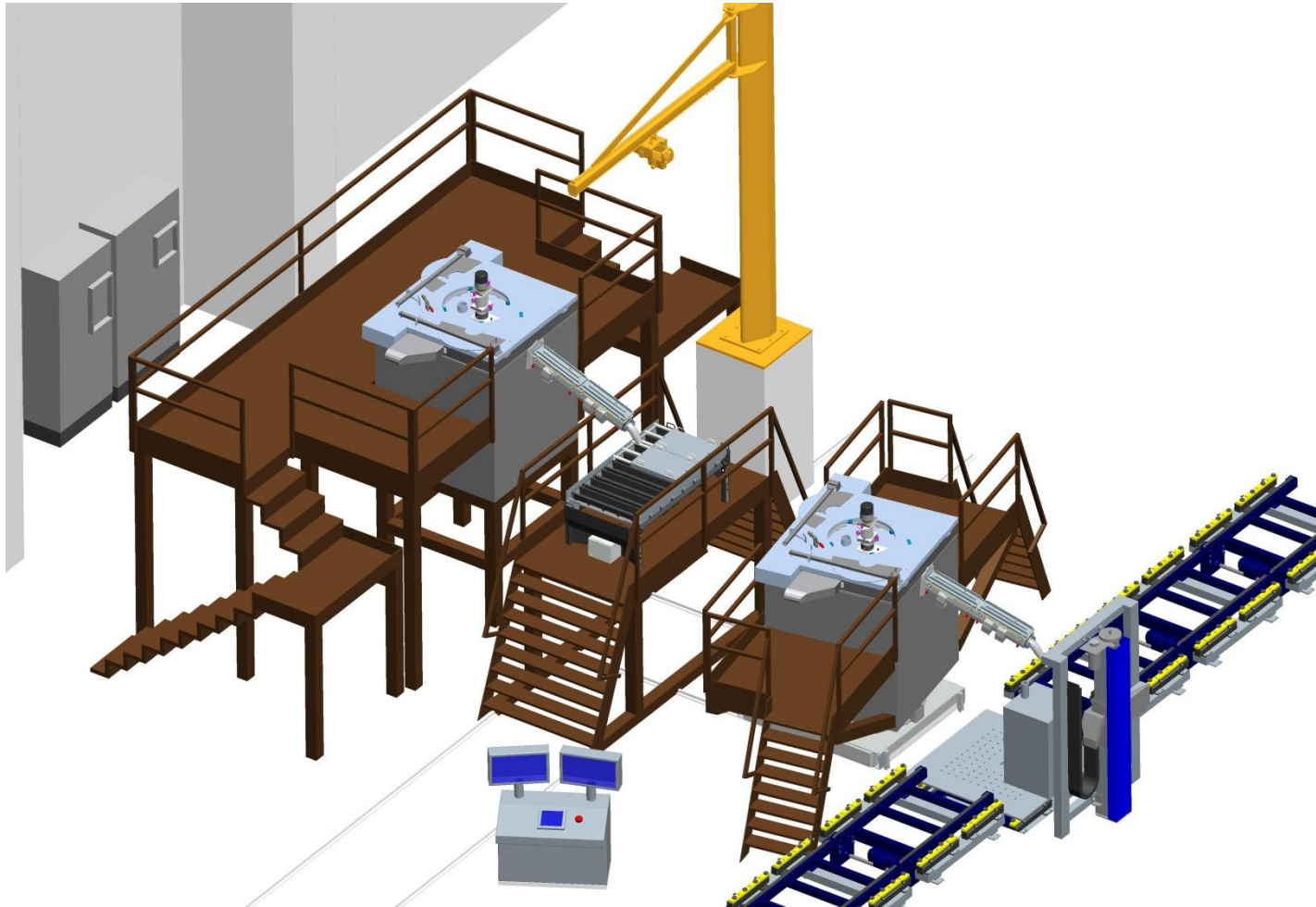



EXAMPLES OF COMPLETED ORDERS

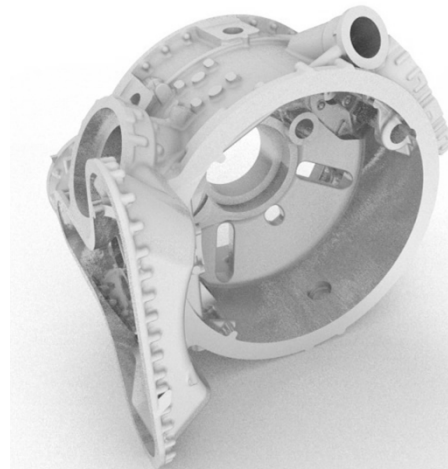
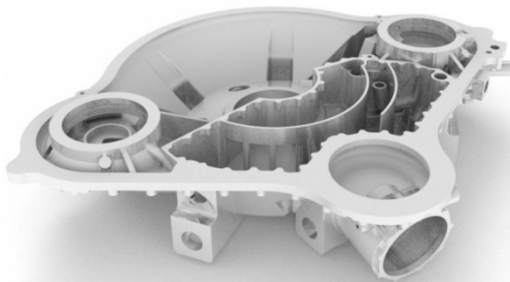
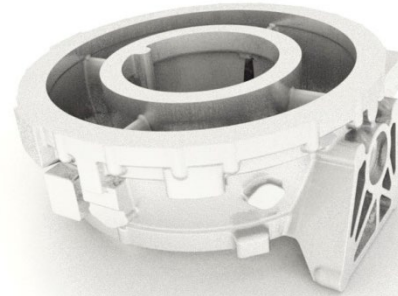
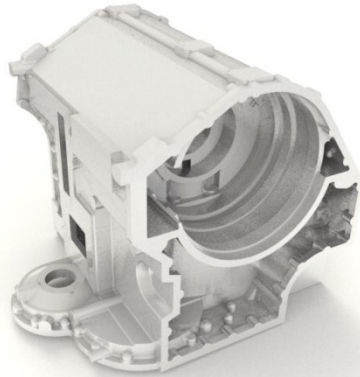

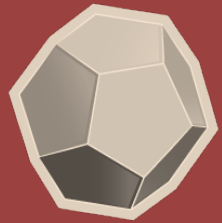
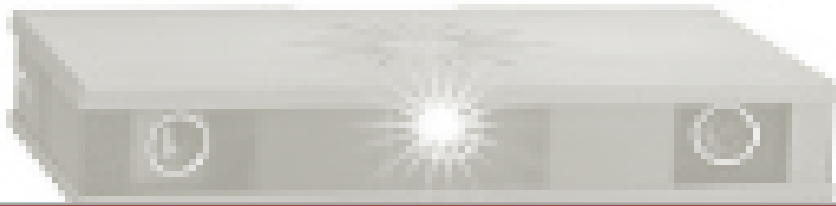

EQUIPMENT OF NONDESTRUCTIVE CONTROL

- OPTICAL SCANNING
- COMPUTER TOMOGRAPHY

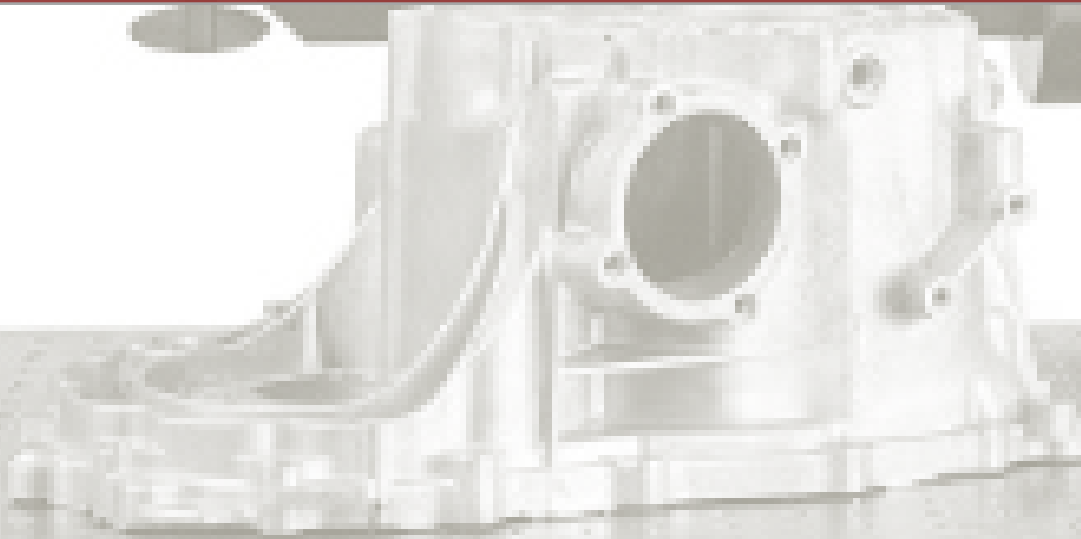



COMPLEX «GEOMETRY CONTROL»

TECHNOLOGICAL COMPLEX OF GEOMETRY CONTROL WITH APPLICATION OF CONTACTLESS OPTICAL SYSTEM

INPUT DATA

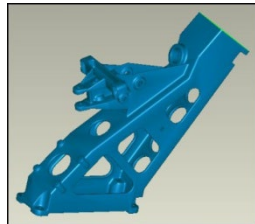

OPTICAL 3D MEASURING MACHINE



REPORT

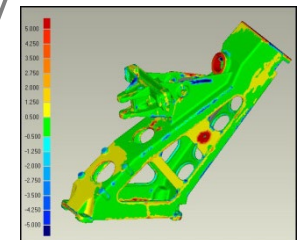
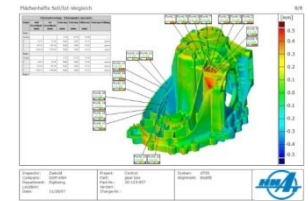



COMPLEX «COMPUTER TOMOGRAPHY»

TECHNOLOGICAL COMPLEX OF NONDESTRUCTIVE CONTROL OF INTERNAL DEFECTS

PART



CONTROLLED
OBJECTS



EQUIPMENT FOR COMPUTER TOMOGRAPHY



REPORT

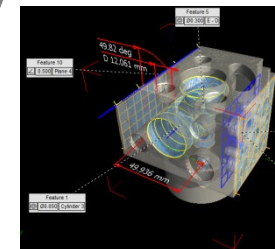
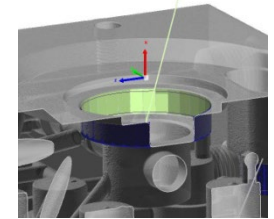
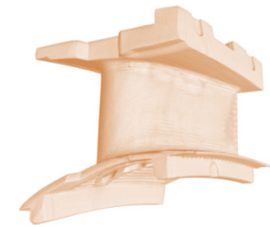

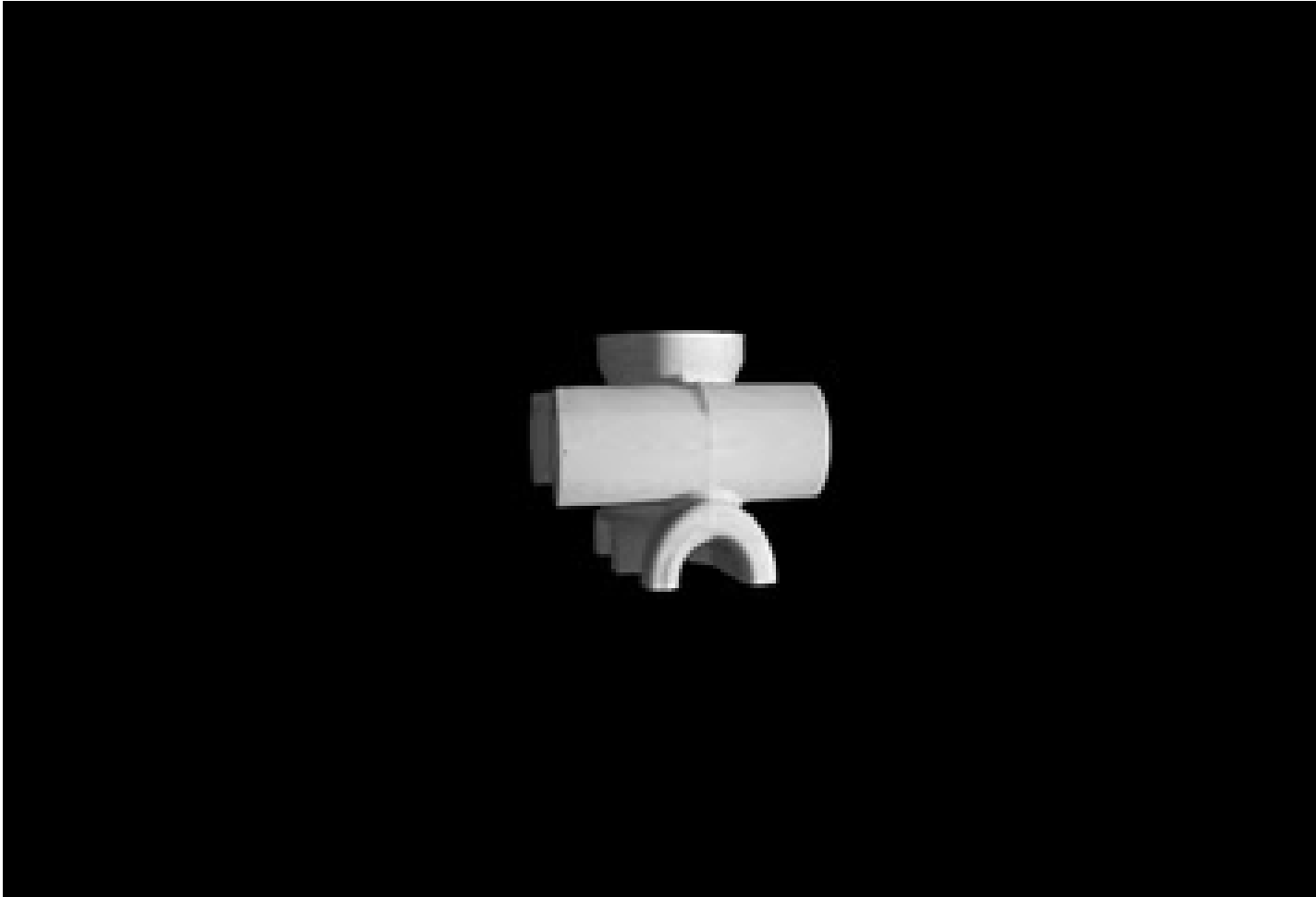

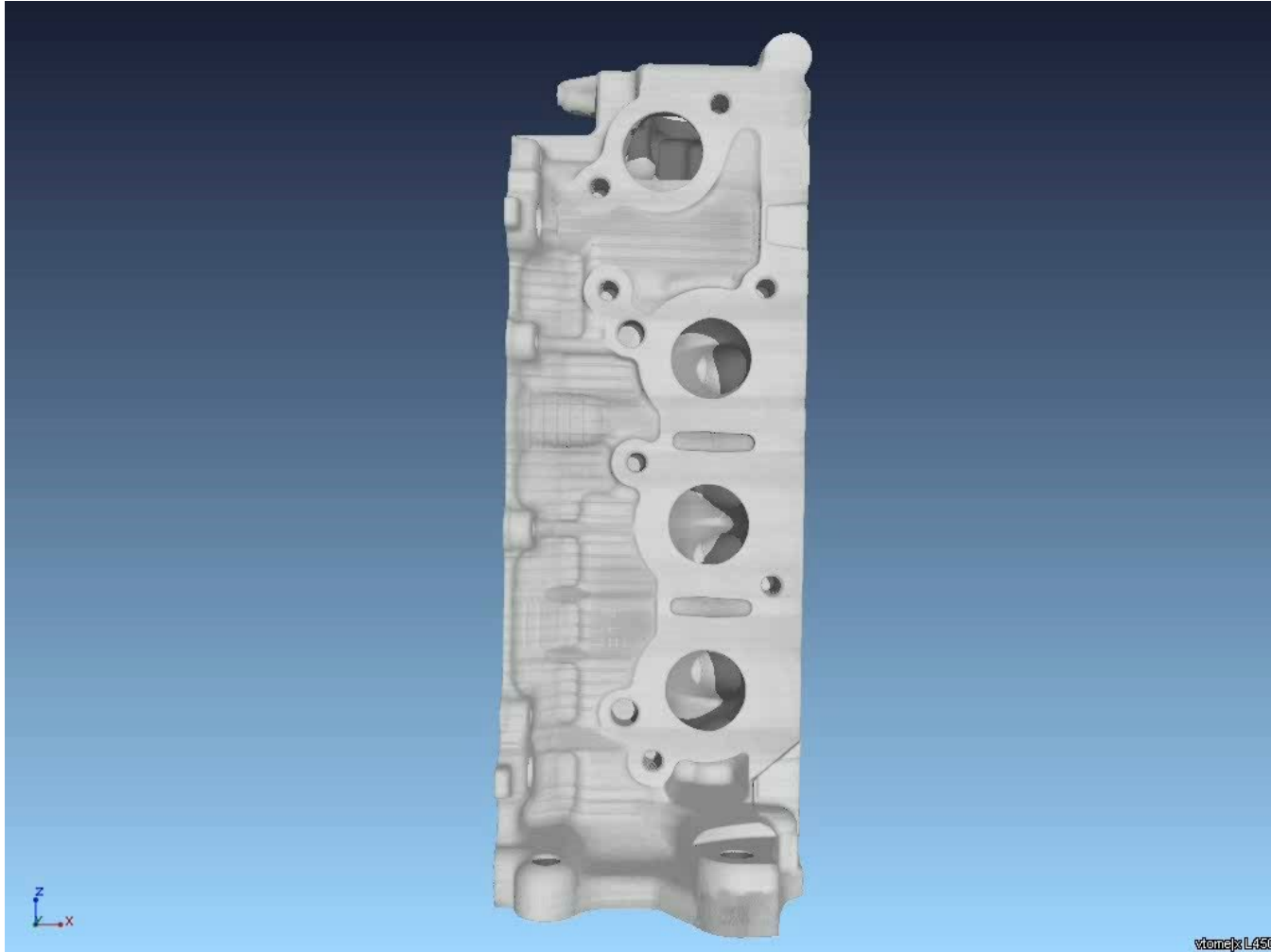



**INDUSTRIAL ADDITIVE
TECHNOLOGY**

- DEVELOPMENT
- IMPLEMENTATION
- MANUFACTURING





PROJECT OF DIGITAL CASTING PLANT TO CAST MG AND AL PARTS «GREENFIELD»





RESEARCH
INDUSTRIAL
COMPLEX
DIGITAL CASTING PRODUCTION

DIGITAL
ADDITIVE
MANUFACTURING





RESEARCH
INDUSTRIAL
COMPLEX
DIGITAL CASTING PRODUCTION

DIGITAL
ADDITIVE
MANUFACTURING

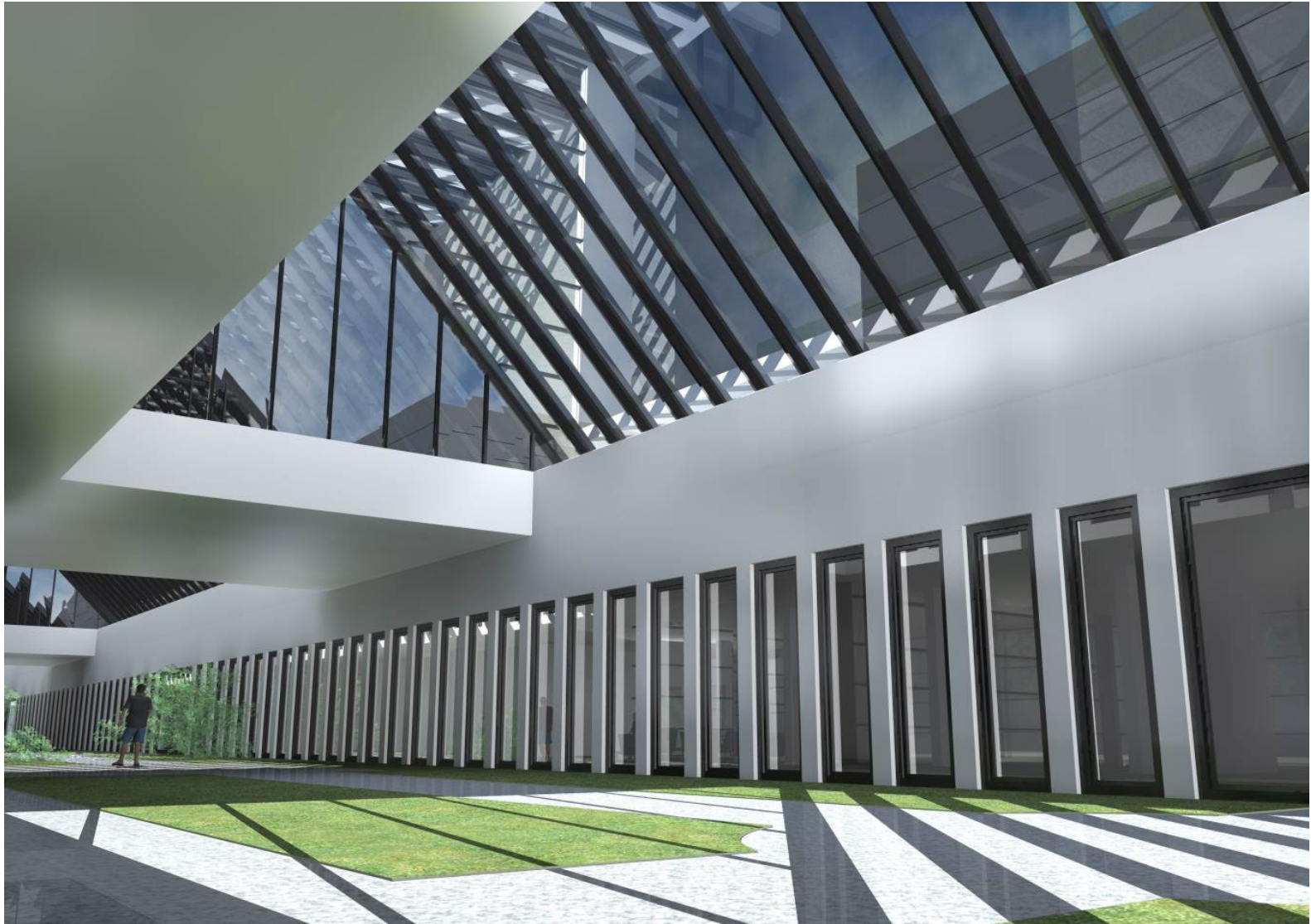



RESEARCH
INDUSTRIAL
COMPLEX
DIGITAL CASTING PRODUCTION

DIGITAL
ADDITIVE
MANUFACTURING

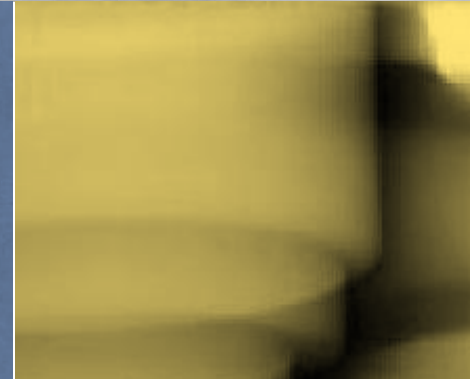
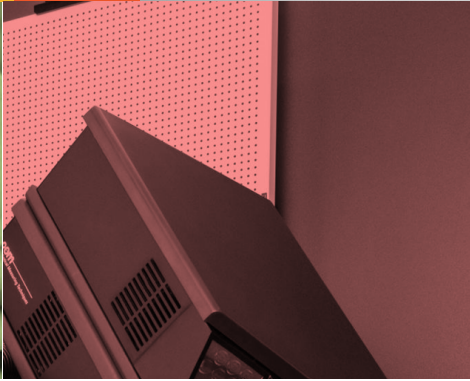

THANK YOU

