

Study on Ultrasonic Vibration Machining with High Efficiency and Accuracy for Less Machinable Materials and New Materials

Fine ceramics have excellent heat resistance and corrosion resistance. However, the development of a new machining technology is an urgent subject because the machinabilities of the ceramics are low. The technology, which machines ceramics in high efficiency and accuracy, is developed by assisting the ultrasonic vibration to the machining as a method of solving this subject. In this research, the ultrasonic vibration of the frequency of 20 kHz to 60 kHz and more are used. Damage by the brittle fracture is controlled by making cutting rubbish a corpuscle; -as a result, a high-quality machining is aimed at.

Construction of machining database on cutting of less machinable materials and new materials assisted by ultrasonic vibration

The same technique in some cases can be combined with focused, high power laser beam, for enabling temporary thermal material-softening. The laser beam is concentrated in the zone of cutting; -just in front of a cutting tool.

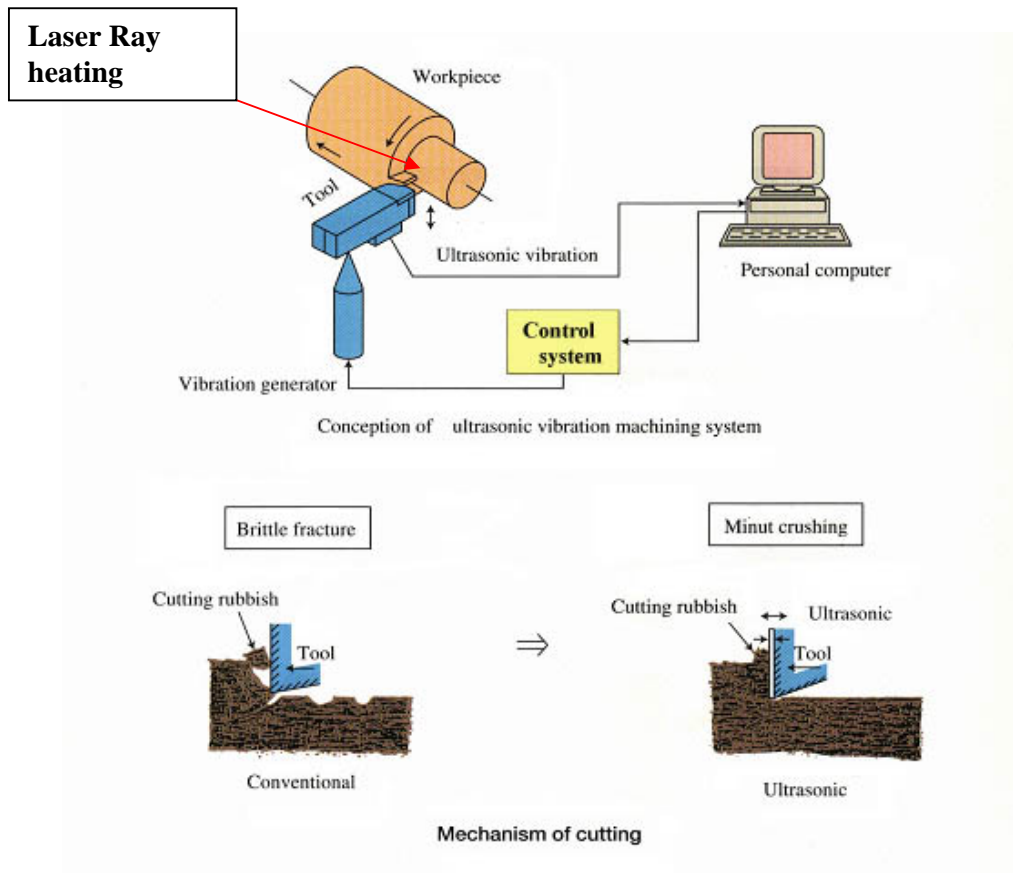

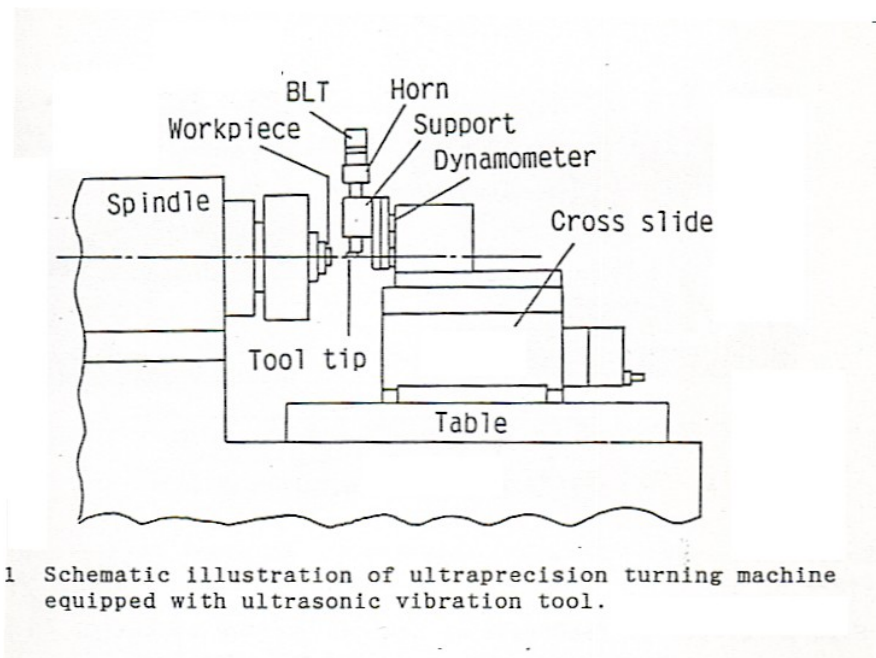
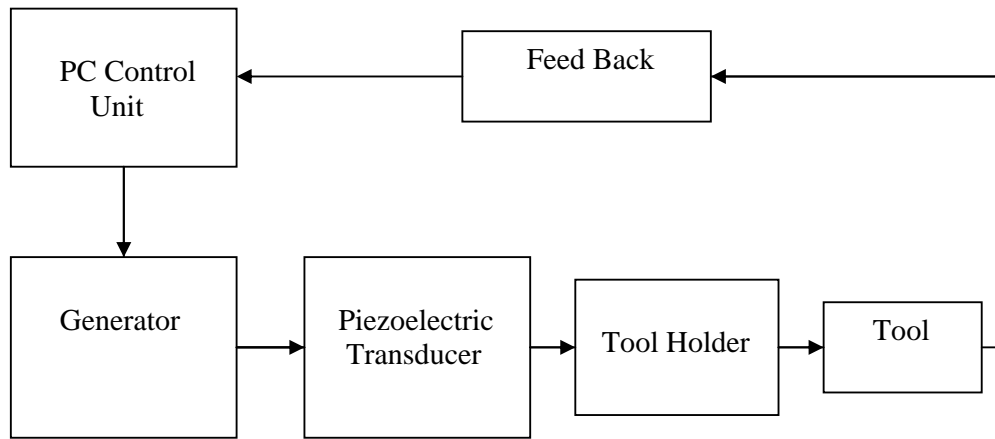

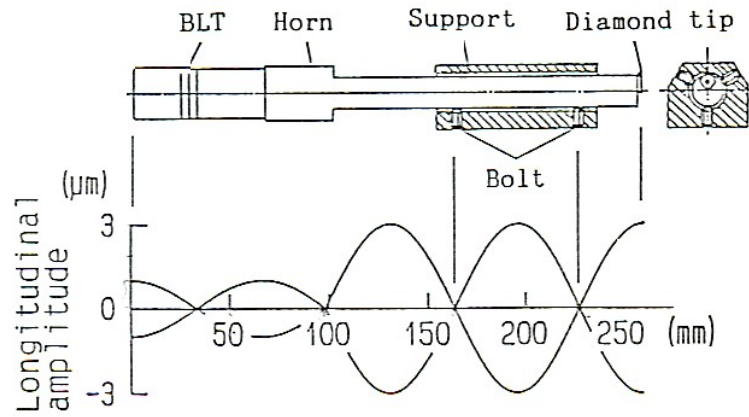

Ultrasonically vibrated tool and resonant mode of vibration.

